

# DATA SHEET

## **SAA7206H** DVB compliant descrambler

Product specification  
Supersedes data of 1996 Oct 02  
File under Integrated Circuits, IC02

1996 Oct 09

---

**DVB compliant descrambler****SAA7206H**

---

**CONTENTS**

|        |                             |
|--------|-----------------------------|
| 1      | FEATURES                    |
| 2      | GENERAL DESCRIPTION         |
| 3      | ORDERING INFORMATION        |
| 4      | QUICK REFERENCE DATA        |
| 5      | BLOCK DIAGRAM               |
| 6      | PINNING                     |
| 7      | FUNCTIONAL DESCRIPTION      |
| 7.1    | MPEG-2 systems parsing      |
| 7.2    | PES level descrambling      |
| 7.3    | Descrambler core            |
| 7.4    | Microcontroller interface   |
| 7.5    | Output interfacing          |
| 7.6    | Boundary scan test          |
| 7.7    | Programming the descrambler |
| 8      | LIMITING VALUES             |
| 9      | HANDLING                    |
| 10     | THERMAL CHARACTERISTICS     |
| 11     | DC CHARACTERISTICS          |
| 12     | AC CHARACTERISTICS          |
| 13     | PACKAGE OUTLINE             |
| 14     | SOLDERING                   |
| 14.1   | Introduction                |
| 14.2   | Reflow soldering            |
| 14.3   | Wave soldering              |
| 14.3.1 | QFP                         |
| 14.3.2 | SO                          |
| 14.3.3 | Method (QFP and SO)         |
| 14.4   | Repairing soldered joints   |
| 15     | DEFINITIONS                 |
| 16     | LIFE SUPPORT APPLICATIONS   |

## DVB compliant descrambler

## SAA7206H

**1 FEATURES**

- Input data fully compliant with the Transport Stream (TS) definition of the MPEG-2 systems specification
- Input data signals; [Forward Error Correction (FEC) Interface]
  - modem data input bus (8-bit wide)
  - valid input data indicator
  - erroneous packet indicator
  - first packet byte indicator
  - byte strobe signal (for asynchronous mode only).

The interface can be programmed to one of two modes:

- Asynchronous mode; byte strobe input signal (MBCLK) < 9 MHz, for connection to a modem (FEC)
- Synchronous mode; MBCLK is not used. Data is delivered to the descrambler synchronized with the chip clock (DCLK) [9 MHz (typ.) with a 33% duty cycle].
- No external memory
- Effective bit rate;  $f_{bit} \leq 72$  MHz
- Control interface; 8-bit multiplexed data/address, memory mapped I/O (90CE201 microcontroller parallel bus compatible), in combination with a microcontroller interrupt signal (IRQ)
- Output ports are identical to the input data interface (demultiplexer interface)
  - except for the packet error indicator ( $\overline{MB}/MB$ ), as the descrambler translates an active MB signal to the 'transport\_error\_indicator' bit in the transport stream
  - except for the byte strobe input signal (MBCLK), as data is delivered to the demultiplexer, synchronized with the descrambler chip clock which is generated by the demultiplexer

- Descrambler, based on the super descrambler mechanism algorithm with stream decipher and block decipher. The descrambler is initialized with a 64-bit Control Word (CW) at the beginning of a transport stream packet payload of a selected Packet Identification (PID). The descrambler operates on transport stream packet or Packetized Elementary Stream (PES) packet payloads
- Microcontroller support; only for control, no specific descrambling tasks are performed by the microcontroller. However, parsing and processing of conditional access information (such as EMM and ECM data) is left to the system microcontroller
- Boundary scan test port for boundary scan.

**2 GENERAL DESCRIPTION**

The SAA7206H (DVB compliant) is designed for use in MPEG-2 based digital TV receivers, incorporating conditional access filters. Such receivers are to be implemented in, for instance, a digital video broadcasting top set box, or an integrated digital TV receiver. An example of a demultiplexer/descrambler system configuration, containing a channel decoder module, a demultiplexer, a system controller and a conditional access system is shown in Fig.3. The main function of the descrambler is to descramble the payloads of MPEG-2 TS packets or PES packets. In addition, the descrambler retrieves Conditional Access (CA) data [such as Entitlement Management Messages (EMM) and Entitlement Control Messages (ECM) etc.] from the stream and passes it to the system microcontroller for processing.

**3 ORDERING INFORMATION**

| TYPE NUMBER | PACKAGE |  |          |
|-------------|---------|--|----------|
|             | NAME    | DESCRIPTION  | VERSION  |
| SAA7206H    | QFP64   | plastic quad flat package; 64 leads (lead length 1.95 mm); body 14 × 20 × 2.8 mm | SOT319-2 |

DVB compliant descrambler

SAA7206H

4 QUICK REFERENCE DATA

| SYMBOL                 | PARAMETER                       | CONDITIONS  | MIN. | TYP. | MAX. | UNIT |
|------------------------|---------------------------------|---|------|------|------|------|
| V <sub>DDD</sub>       | digital supply voltage          |   | –    | –    | 5.5  | V    |
| V <sub>DDD(core)</sub> | digital supply voltage for core |   | –    | –    | 3.6  | V    |
| P <sub>tot</sub>       | total power dissipation         | V <sub>DDD(core)</sub> = 3.3 V,<br>V <sub>DDD</sub> = 5 V, C <sub>L</sub> = 15 pF | –    | –    | 250  | mW   |
| f <sub>clk</sub>       | clock frequency                 | duty cycle = 30 to 55%  | –    | –    | 9    | MHz  |
| T <sub>amb</sub>       | operating ambient temperature   |   | 0    | –    | 70   | °C   |

5 BLOCK DIAGRAM

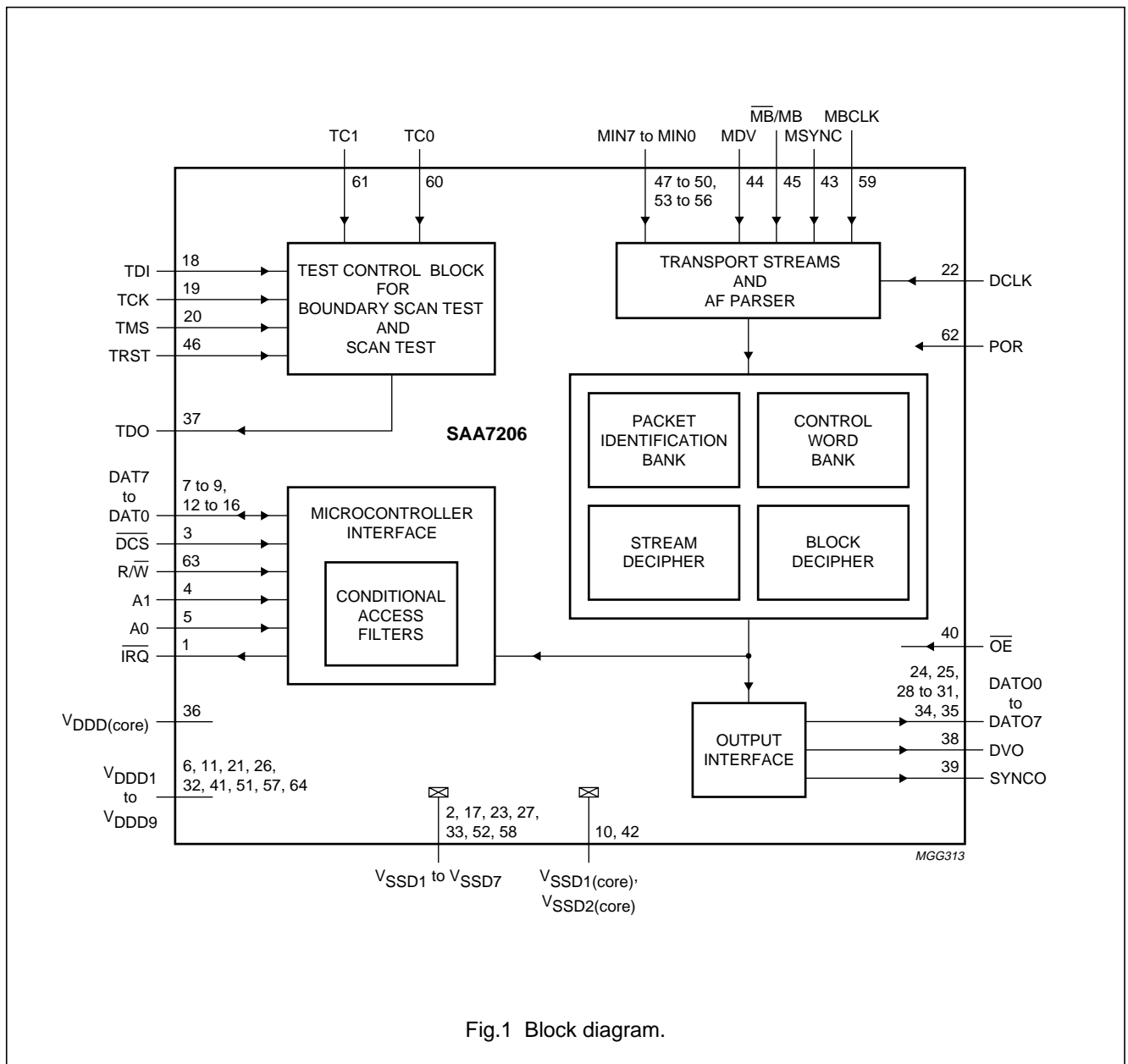

Fig.1 Block diagram.

## DVB compliant descrambler

## SAA7206H

## 6 PINNING

| SYMBOL                  | PIN | I/O    | DESCRIPTION  |
|-------------------------|-----|--------|--|
| $\overline{\text{IRQ}}$ | 1   | O      | interrupt request output for microcontroller (active LOW, open-drain output) |
| $V_{\text{SSD1}}$       | 2   | GND    | digital ground 1   |
| $\overline{\text{DCS}}$ | 3   | I      | descrambler chip select input (active LOW)                                   |
| A1                      | 4   | I      | A1 = address/data indicator input  |
| A0                      | 5   | I      | A0 = MSByte indicator input  |
| $V_{\text{DDD1}}$       | 6   | supply | digital supply voltage 1 (+5 V)  |
| DAT7                    | 7   | I/O    | microcontroller bidirectional data bus bit 7                                 |
| DAT6                    | 8   | I/O    | microcontroller bidirectional data bus bit 6                                 |
| DAT5                    | 9   | I/O    | microcontroller bidirectional data bus bit 5                                 |
| $V_{\text{SSD1(core)}}$ | 10  | GND    | digital ground 1 for core  |
| $V_{\text{DDD2}}$       | 11  | supply | digital supply voltage 2 (+5 V)  |
| DAT4                    | 12  | I/O    | microcontroller bidirectional data bus bit 4                                 |
| DAT3                    | 13  | I/O    | microcontroller bidirectional data bus bit 3                                 |
| DAT2                    | 14  | I/O    | microcontroller bidirectional data bus bit 2                                 |
| DAT1                    | 15  | I/O    | microcontroller bidirectional data bus bit 1                                 |
| DAT0                    | 16  | I/O    | microcontroller bidirectional data bus bit 0                                 |
| $V_{\text{SSD2}}$       | 17  | GND    | digital ground 2   |
| TDI                     | 18  | I      | boundary scan test data input  |
| TCK                     | 19  | I      | boundary scan test clock input   |
| TMS                     | 20  | I      | boundary scan test mode select input   |
| $V_{\text{DDD3}}$       | 21  | supply | digital supply voltage 3 (+5 V)  |
| DCLK                    | 22  | I      | 9 MHz descrambler chip clock input (duty cycle range: 30 to 55%)             |
| $V_{\text{SSD3}}$       | 23  | GND    | digital ground 3   |
| DAT00                   | 24  | O      | data output to demultiplexer bit 0   |
| DAT01                   | 25  | O      | data output to demultiplexer bit 1   |
| $V_{\text{DDD4}}$       | 26  | supply | digital supply voltage 4 (+5 V)  |
| $V_{\text{SSD4}}$       | 27  | GND    | digital ground 4   |
| DAT02                   | 28  | O      | data output to demultiplexer bit 2   |
| DAT03                   | 29  | O      | data output to demultiplexer bit 3   |
| DAT04                   | 30  | O      | data output to demultiplexer bit 4   |
| DAT05                   | 31  | O      | data output to demultiplexer bit 5   |
| $V_{\text{DDD5}}$       | 32  | supply | digital supply voltage 5 (+5 V)  |
| $V_{\text{SSD5}}$       | 33  | GND    | digital ground 5   |
| DAT06                   | 34  | O      | data output to demultiplexer bit 6   |
| DAT07                   | 35  | O      | data output to demultiplexer bit 7   |
| $V_{\text{DDD(core)}}$  | 36  | supply | digital supply voltage for core (+3.3 V)                                     |
| TDO                     | 37  | O      | boundary scan test data output   |
| DVO                     | 38  | O      | valid output data indicator  |
| SYNCO                   | 39  | O      | indicates the first output byte (sync) of a transport packet                 |

## DVB compliant descrambler

## SAA7206H

| SYMBOL             | PIN | I/O    | DESCRIPTION  |
|--------------------|-----|--------|--|
| $\overline{OE}$    | 40  | I      | output enable (active LOW), if HIGH, device outputs are high impedance, (connected to logic 0 in normal operation) |
| $V_{DD6}$          | 41  | supply | digital supply voltage 6 (+5 V)  |
| $V_{SS2(core)}$    | 42  | GND    | digital ground 2 for core  |
| MSYNC              | 43  | I      | indicates the first input byte (sync) of a transport packet  |
| MDV                | 44  | I      | valid input data indicator   |
| $\overline{MB}/MB$ | 45  | I      | packet error indicator input (programmable polarity)   |
| TRST               | 46  | I      | boundary scan reset input (LOW in normal operation)  |
| MIN7               | 47  | I      | 8-bit wide modem data input bit 7  |
| MIN6               | 48  | I      | 8-bit wide modem data input bit 6  |
| MIN5               | 49  | I      | 8-bit wide modem data input bit 5  |
| MIN4               | 50  | I      | 8-bit wide modem data input bit 4  |
| $V_{DD7}$          | 51  | supply | digital supply voltage 7 (+5 V)  |
| $V_{SS6}$          | 52  | GND    | digital ground 6   |
| MIN3               | 53  | I      | 8-bit wide modem data input bit 3  |
| MIN2               | 54  | I      | 8-bit wide modem data input bit 2  |
| MIN1               | 55  | I      | 8-bit wide modem data input bit 1  |
| MIN0               | 56  | I      | 8-bit wide modem data input bit 0  |
| $V_{DD8}$          | 57  | supply | digital supply voltage 8 (+5 V)  |
| $V_{SS7}$          | 58  | GND    | digital ground 7   |
| MBCLK              | 59  | I      | byte strobe input signal < 9 MHz   |
| TC0                | 60  | I      | test control input 0 (not connected in normal operation)   |
| TC1                | 61  | I      | test control input 1 (not connected in normal operation)   |
| POR                | 62  | I      | power-on reset, must be active HIGH during at least 5 DCLK pulses  |
| $R/\overline{W}$   | 63  | I      | read/write input selection   |
| $V_{DD9}$          | 64  | supply | digital supply voltage 9 (+5 V)  |

DVB compliant descrambler

SAA7206H

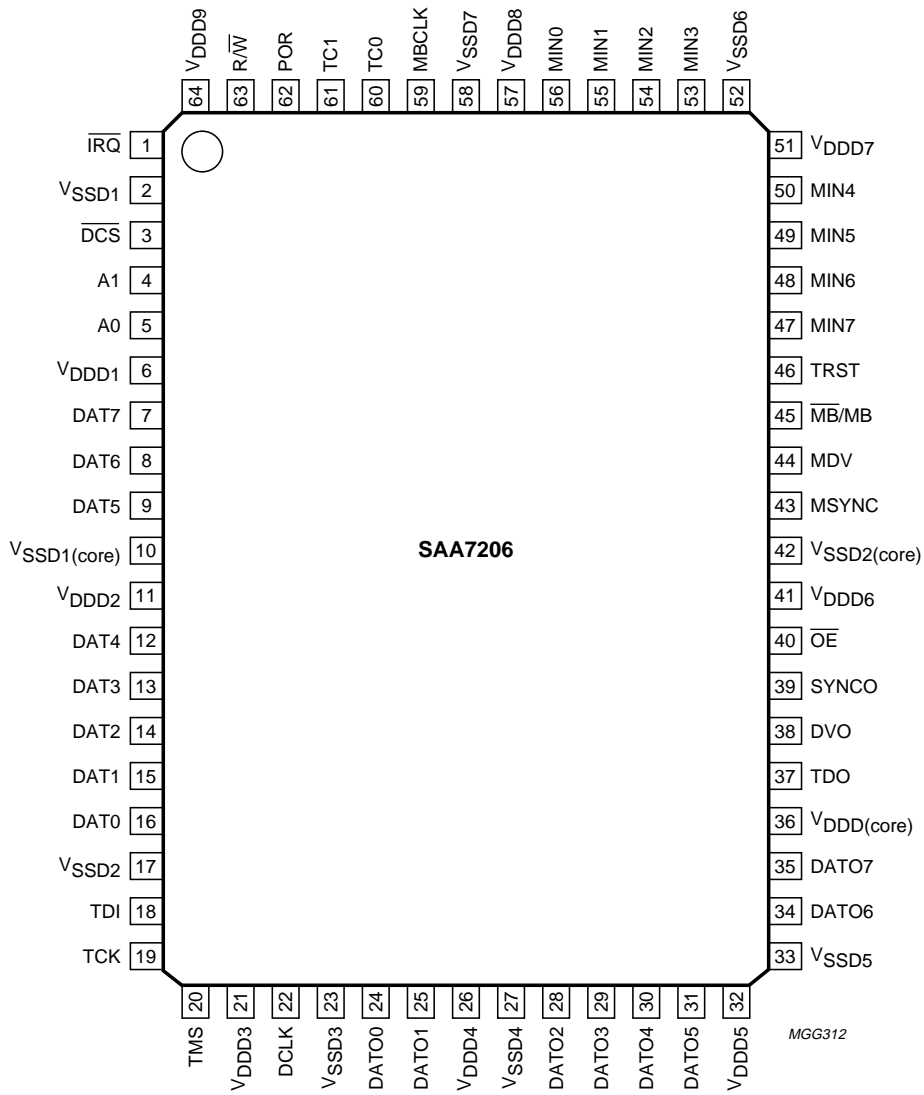

Fig.2 Pin configuration.

# DVB compliant descrambler

# SAA7206H

## 7 FUNCTIONAL DESCRIPTION

A block diagram of the internal structure of the descrambler (DVB compliant) is illustrated in Fig.1. The block diagram illustrates the main functional modules in the descrambler. The modules are as follows:

- The MPEG-2 syntax parser, which parses transport streams that comply with the MPEG-2 systems specification
- The descrambler module consisting of:
  - A Packet Identification (PID) bank containing 6 PID values of the streams selected for descrambling. All bits of PID5 (address 0x0205) can be masked individually with PID5\_mask (address 0x0209), to enable multiple PID selection.
  - A Control Word (CW) bank containing 6 CW pairs and a default CW. A CW pair consists of 2 descrambler control words (odd and even), each word with a length of 64 bits.
  - The descrambler core containing the actual descrambler with the stream cipher and the block cipher module.
- A microcontroller interface providing protocol handling for the memory mapped I/O control bus (Philips 90CE201 compatible). This module contains an interrupt request handler and data filters for the retrieval of Conditional Access (CA) information:

- The CA filters select data on the basis of PIDs, and a combination of MPEG-2 section addressing fields. Selected CA data is stored in eighteen 256 byte (constrained random access) buffers which can be read by the microcontroller. The CA message section has a maximum length of 256 bytes. It consists of a 3 bytes long header with Table\_id and section\_length data. The remaining part of the CA message are the CA\_data\_bytes (see Fig.4). If a section is longer than 256 bytes, the data capture is stopped (with an interrupt to the microcontroller) after 256 bytes are in the buffer and the 'section\_to\_long' bit is set. The filters are capable of monitoring 18 CA streams (containing EMM and ECM data) simultaneously. Two different lengths are used for address filtering:
  - 16 filters where the first 7 bytes of the CA\_data\_bytes field are used for address filtering
  - 2 (DVB compliant) filters where the first 17 bytes of the CA\_data\_bytes field are used for address filtering
  - A chip identification byte (value 0x02) can be read by the software from address 0x0003 (see Table 10).

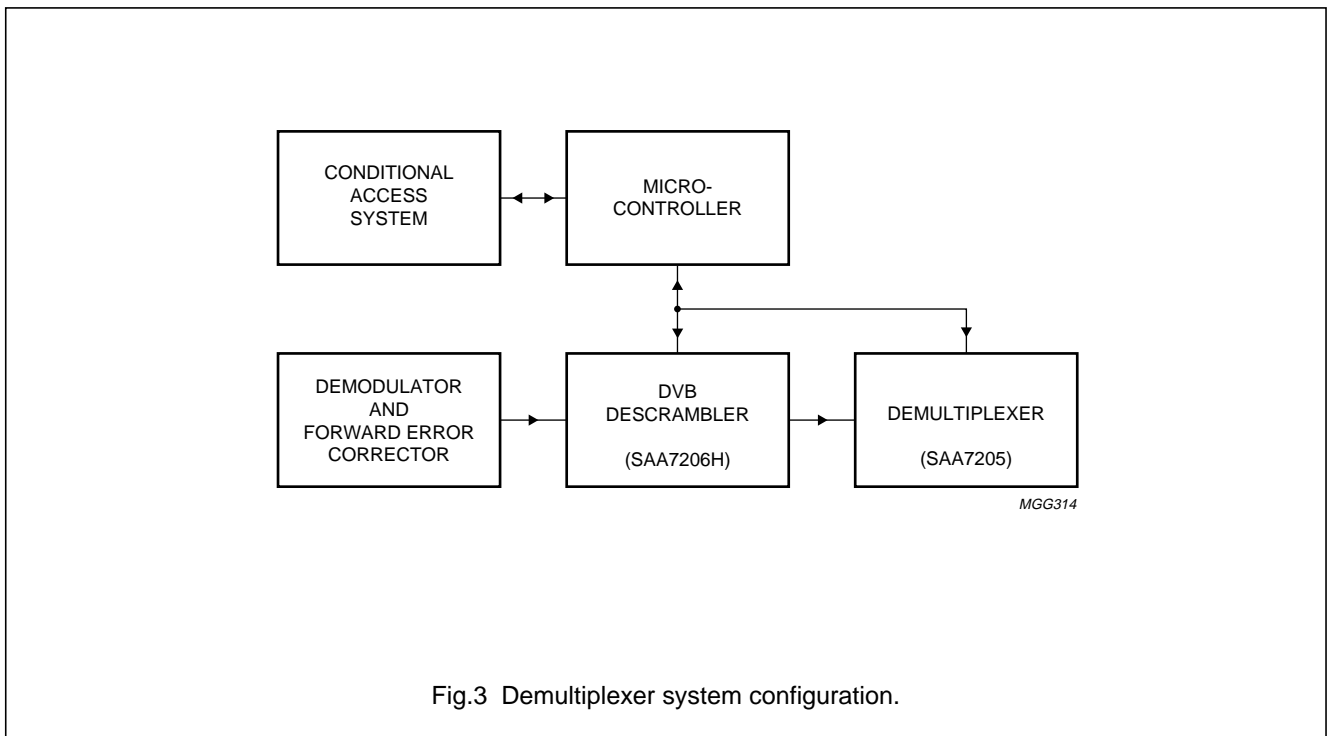

Fig.3 Demultiplexer system configuration.



DVB compliant descrambler

SAA7206H

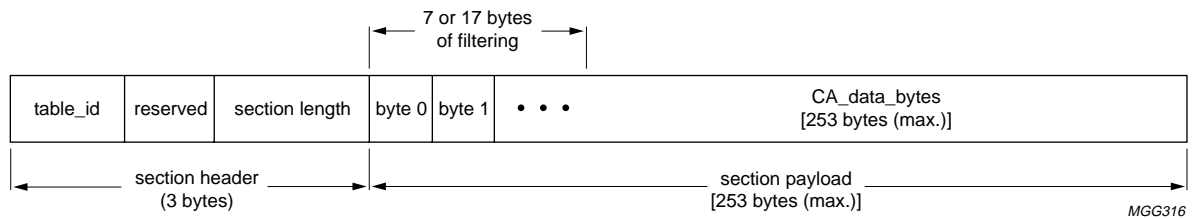

Fig.4 Syntax of the conditional access message.

Table 1 Explanation of Fig.4

| SYNTAX         | DESCRIPTION   |
|----------------|---|
| Table_id       | 8-bit field for identification  |
| Reserved       | 4-bit field with section_syntax_indicator (1 bit), DVB_reserved (1 bit) and ISO_reserved (2 bits)                   |
| Section_length | 12-bit field that specifies the number of bytes that follow the section_length field up to the end of the section   |
| CA_data_byte   | 8-bit field that carries private CA information. Up to the first 17 CA_data_bytes may be used for address filtering |

## DVB compliant descrambler

## SAA7206H

### 7.1 MPEG-2 systems parsing

The descrambler receives data from a Forward Error Correction (FEC) decoder (see Fig.5) in a digital TV receiver, in the following input data format:

- 8 data bits via MIN7 to MIN0.
- A valid input data indicator signal (MDV), which is HIGH for consecutive valid bytes and output by either a FEC decoder or a descrambler. Consequently the descrambler input data is allowed to have a 'bursty' nature.
- A transport packet error indicator ( $\overline{\text{MB}}/\text{MB}$ ) which is HIGH for the duration of each 188 byte transport packet in which the FEC decoder found more errors than it could correct. The polarity (active HIGH or LOW) of the error indicator is programmable [bit 'Bad\_polarity' (see Table 10, address 0x0100)].
- A packet sync signal (MSYNC) which goes HIGH at the start of the first byte of a transport packet. Only the rising edge of MSYNC is used for synchronization, the exact HIGH time of the signal is therefore irrelevant.
- A byte strobe signal (MBCLK; < 9 MHz) which indicates consecutive data bytes in the input stream, in the non 9 MHz mode only [bit '9 MHz\_interface' = 0 (see Table 10, address 0x0100)]. MBCLK is used as an enable signal, and transport stream input bytes are sampled on its rising edges. If the input interface is programmed to the 9 MHz mode ('9 MHz\_interface' = 1), the MBCLK signal is ignored and bytes are latched on rising edges of the DCLK.
- A descrambler clock signal (DCLK; 9 MHz; duty cycle range 30 to 55%) which is the processing clock for the descrambler IC. If rising edges of this signal are used to input data to the descrambler, the 9 MHz mode must be programmed (bit '9 MHz\_interface' = 1, see Table 10, address 0x0100).

The parser module in the descrambler parses transport streams compliant to the MPEG-2 systems syntax. MPEG-2 systems specifies a hierarchical two-level multiplex (see Fig.6). The top hierarchical level is the transport stream, consisting of relatively short (188 byte) transport packets. Each transport packet consists of a 4 byte transport header, an optional adaptation field and a payload. The transport header contains a 13-bit PID field. The adaptation field may contain Program Clock Reference (PCR) data and transport private data, among others. Both transport header and optional adaptation fields are parsed by the TS parser module.

The hierarchical multiplex level below the MPEG-2 transport stream is the packetized elementary stream. The PES header is only parsed partially by the DVB descrambler to locate its scrambling control bits. Parsing is performed for all incoming transport packets, and the parser is synchronized to a rising edge on its MSYNC input. A microcontroller can compose a set of 6 PIDs by programming the appropriate registers in the PID filter bank within the descrambler.

These PIDs identify the packets of the streams that are to be descrambled. All 13 bits of PID5 (see Table 10, address 0x0205) can be individually enabled/disabled with a mask of 13 bits (see Table 10, address 0x0209) to enable multiple PID selection. The PIDs of PES scrambled packets must be indicated by programming a logic 1 to the corresponding bit of the 'PIDi\_is\_pes' word (see Table 10, address 0x0206).

MPEG-2 multiplex fields which are related to CA information, in so called sections, are parsed only partly. CA sections containing for instance Entitlement Management Messages (EMM) and Entitlement Control Messages (ECM) etc. are retrieved from the stream and stored in 256 byte buffers in the CA filter module. For the selection of CA data, 18 additional PIDs and section header information (table\_id, address field, both with bit masks) can be programmed. All 13 bits of PID filters 16 and 17 can be individually enabled/disabled with a mask of 13 bits (see Table 10, addresses 0x03A6 and 0x03BA) to enable multiple PID selection for CA messages. A microcontroller may access data in the 256 byte CA buffers (each filter has its own buffer thus 18 in total) for software based parsing and processing.

DVB compliant descrambler

SAA7206H

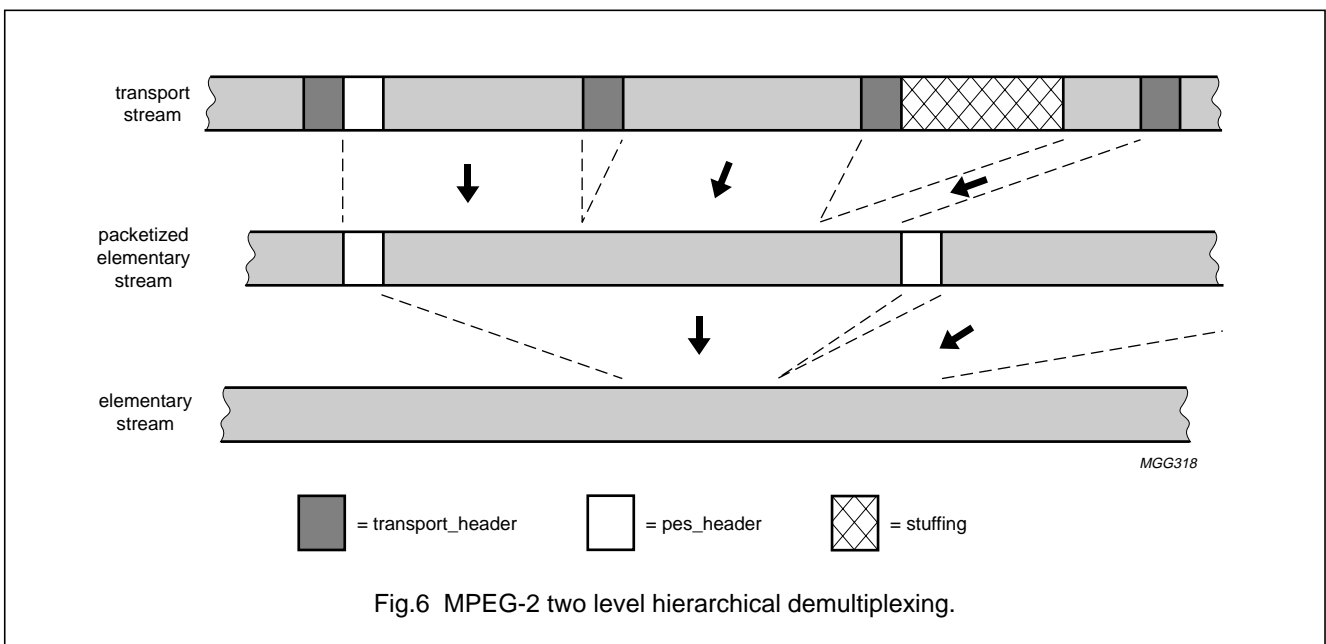
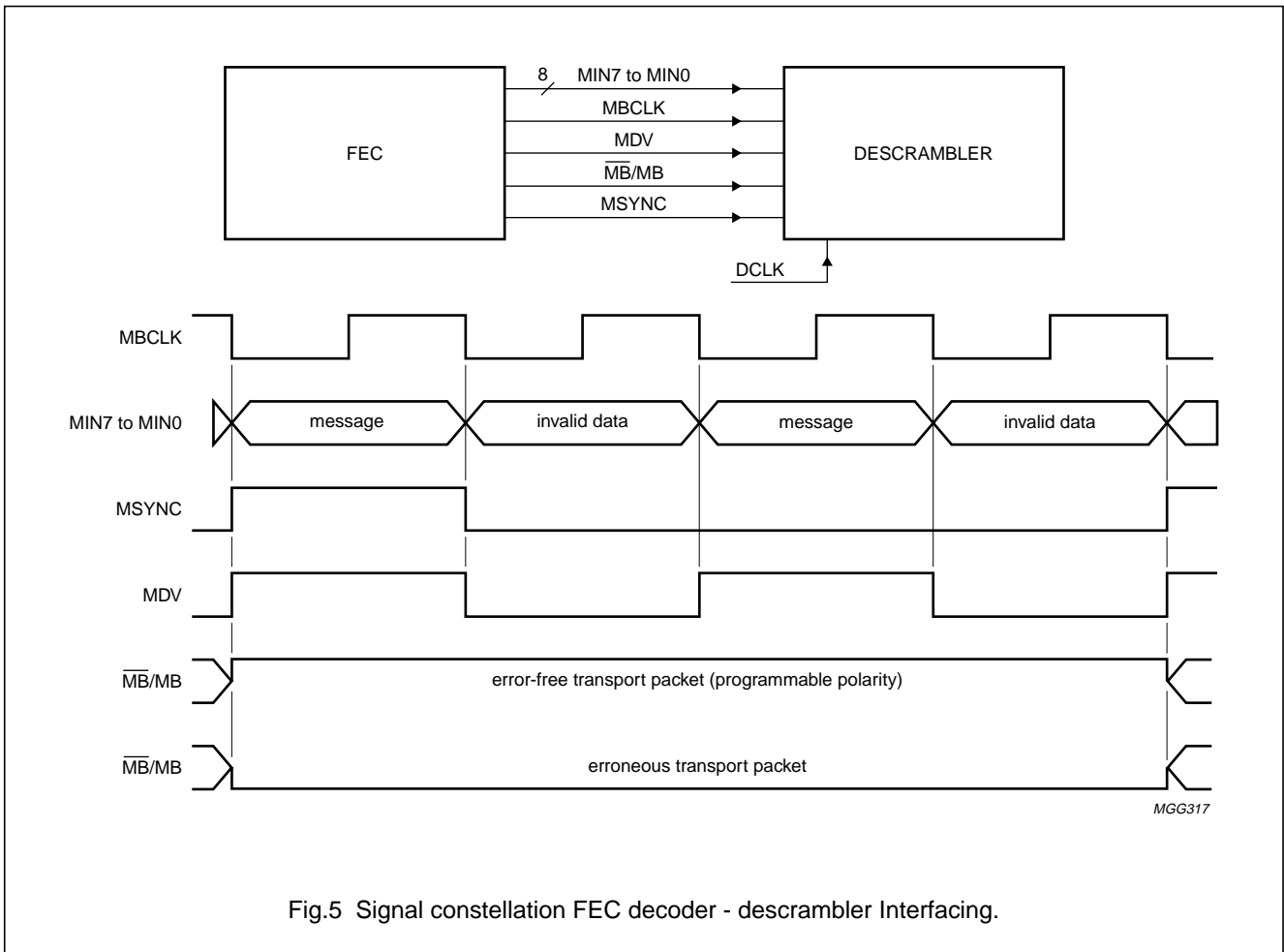

## DVB compliant descrambler

## SAA7206H

### 7.2 PES level descrambling

PES level descrambling is possible in accordance with the recommendations of the DVB standard with the DVB descrambler IC. The actual restrictions however, required by the DVB descrambler IC, are less strict than to the recommendations in the DVB standard. The restrictions for PES level descrambling imposed by the IC are as follows:

- Scrambling shall only occur at one level (TS or PES) and is not allowed to occur at both levels simultaneously
- The complete PES header must be present in exactly one TS packet. Consequently, the size of a PES packet header shall not exceed 184 bytes
- Only the PES packet data bytes (PES payload) are descrambled
- TS packets resulting from scrambling at PES level are not chained and thus are independent. Consequently, the internal descrambler algorithms (stream decipher and block decipher) are initialized at the start of each (PES scrambled) TS packet payload.

In order to be able to distinguish between sections and PES packets, a PID for a PES scrambled packet is indicated by programming the according 'PIDI\_is\_pes' bit (see Table 10, address 0x0206) to logic 1. If the payload\_unit\_start\_indicator bit is set in the TS packet header and the 'PIDI\_is\_pes' bit is set for a particular PID, the PES scrambling control bits, which are present in the PES header, are stored in the accessible 'pes\_sc\_PIDI' register (see Table 10, address 0x0208).

Descrambling at TS level always has priority over descrambling at PES level. Consequently, PES level descrambling is only possible when the transport\_scrambling\_control bits in the TS header are '00'. In that situation the payload of the PES packets is descrambled using the scrambling control bits of the 'pes\_sc\_PIDI' register.

**Remark:** PID masking (for PID5) should not be combined with PES level descrambling. Only one pair of PES scrambling control bits per PID is stored in an Internal register. Thus interleaving of PES messages, which can occur in the situation of multiple PID selection, can give the wrong descrambling result. As a consequence the microcontroller must program the 'PID5\_is\_pes' bit (see Table 10, address 0x0206) to logic 0 when multiple PID selection is used.

### 7.3 Descrambler core

The descrambler core consists of three modules:

- A PID filter which selects packets for descrambling
- A control word bank containing 6 sets (odd and even) of control words and a Default Control Word (DCW)
- The super descrambler core with the implementation of the stream decipherment and the block decipherment algorithms.

The PID filter contains 6 registers which hold data in the format indicated in Fig.7. Six individual PIDs are stored to identify 6 packet streams. All bits of PID5 (see Table 10, address 0x0205) can be masked with the 'PID5\_mask' (see Table 10, address 0x209), to enable descrambling on multiple PIDs. To disable a bit of PID5 with the 'PID5\_mask' a logic 0 must be programmed. After a power-on reset pulse all mask bits are preset to logic 1.

To each PID a 3-bit Control Word Pair Index pointer (CWPI) is attached. A CWPI prescribes which control word pair, consisting of odd and even control words, has to be used to initialize the DVB descrambler for payloads of packets with the associated PID. After a power-on reset all CWPIs are set to '111' to enable a correct initialization of the conditional access system.

If two or more programmed PIDs match the PID of the TS packet at the same time (while the CWPI value of the programmed PIDs is not equal to '110' or '111'), the programmed PID with the lower index number has a higher priority. However, the default control word, when enabled, has the highest priority.

Thus, the built-in priority (HIGH-to-LOW transition) for the programmed PIDs is; DCW, PID0, PID1, PID2, PID3, PID4 and PID5.

A 2-bit scrambling\_control field is present in the TS packet header and in the PES header (ts\_sc1 and ts\_sc0 and pes\_sc1 and pes\_sc0 respectively). The bits in this header field indicate whether the TS packet or PES payload is scrambled or not. In addition, these bits also indicate which control word (odd or even) of a control word pair was used to initialize the DVB descrambler, as indicated in Tables 2 and 3.

## DVB compliant descrambler

## SAA7206H

If the payload of a packet is descrambled, the descrambler subsequently resets the scrambling\_control bits in the TS or PES header (to '00'). For each of the 6 PIDs in the PID filter bank the values of the TS scrambling\_control bits are stored in a microcontroller accessible register, prior to descrambling [bits: 'ts\_sc\_PIDi1' and 'ts\_sc\_PIDi0'; (see Table 10, address 0x0208), 'i' is in the range 5 to 0]. For each of the 6 PIDs in the PID filter bank, of which the corresponding PIDi\_is\_pes bit (see Table 10, address 0x0206) is also set to logic 1, the values of the PES scrambling\_control bits are stored in a microcontroller accessible register, prior to descrambling [bits: 'pes\_sc\_PIDi1' and 'pes\_sc\_PIDi0' (see Table 10, address 0x0208) 'i' is in the range 5 to 0]. TS and PES scrambling\_control retrieval is independent of the value of the CWPI.

**Table 2** Definition of the bits in the PES scrambling\_control field

| VALUE | DESCRIPTION                                  |
|-------|--|
| 00    | data is not scrambled                        |
| 01    | data is not scrambled                        |
| 10    | data is scrambled with the EVEN control word |
| 11    | data is scrambled with the ODD control word  |

**Table 3** Definition of the bits in the TS scrambling\_control field

| VALUE | DESCRIPTION                                     |
|-------|---|
| 00    | data is not scrambled                           |
| 01    | data is scrambled with the default control word |
| 10    | data is scrambled with the EVEN control word    |
| 11    | data is scrambled with the ODD control word     |

**Remark:** The payloads of packets with TS scrambling\_control bits equal to '01' are descrambled using the default control word, regardless of their PID and/or CWPI values. Thus, even PIDs which are not programmed in the PID filter bank are descrambled with the DCW should transport\_scrambling\_control = '01'. For PIDs in the PID filter bank, if transport\_scrambling\_control = '01', the payload is descrambled with the default control word, regardless of the value of the associated CWPI. If the default CW is invalid however ['DCW\_valid' = 0 (see Table 10, address 0x0206)], DCW based descrambling is disabled. Descrambling using the DCW is only possible on TS packet level.

The control word bank contains storage space for 6 control word pairs and a default control word. A control word pair consists of 2 CWs and an odd and even CW, as indicated in Table 4. A control word contains 64 bits. In conjunction with the control word selection mechanism given in Table 4, the CW bank allows any CW pair to be used with any PID. All PIDs may, therefore, use their own specific CW pair, but all of them may also share one CW pair.

The super descrambler algorithm is implemented in the core of the descrambler. Descrambling is performed on the payload of a transport packet or a PES. The transport header, the (optional) adaptation field and the PES header are excepted.

DVB compliant descrambler

SAA7206H

**Table 4** Descrambler control word storage; see Table 10

| CONTROL WORD (128 BITS) |                     | ADDRESS          |
|-------------------------|---------------------|------------------|
| Control word 0 odd      | Control word 0 even | 0x1000 to 0x1007 |
| Control word 1 odd      | Control word 1 even | 0x1008 to 0x100F |
| Control word 2 odd      | Control word 2 even | 0x1010 to 0x1017 |
| Control word 3 odd      | Control word 3 even | 0x1018 to 0x101F |
| Control word 4 odd      | Control word 4 even | 0x1020 to 0x1027 |
| Control word 5 odd      | Control word 5 even | 0x1028 to 0x102F |
| Default control word    | –                   | 0x1030 to 0x1033 |

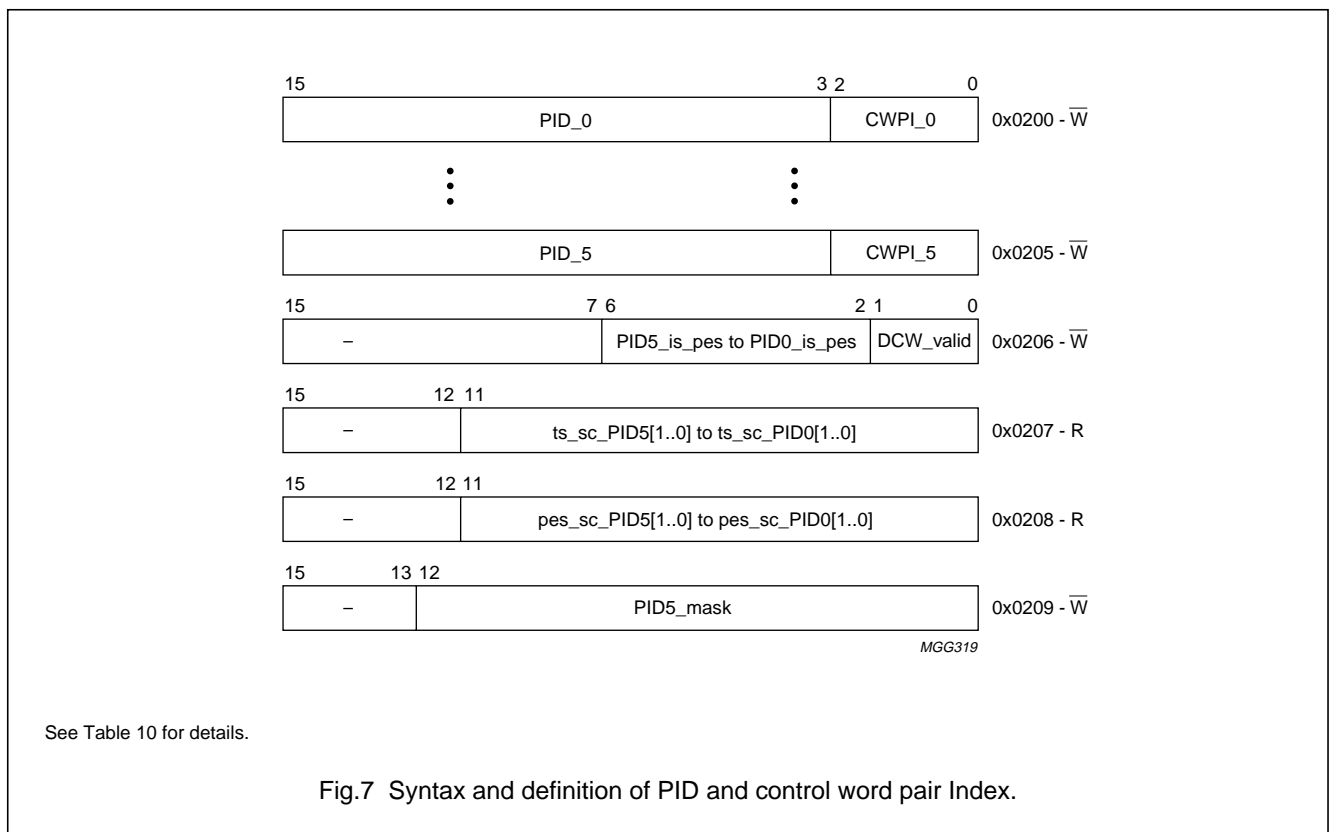

**Table 5** CWPI values; see Fig.7

| CWPI VALUE | DESCRIPTION                |
|------------|----------------------------|
| 0 0 0      | select control word pair 0 |
| 0 0 1      | select control word pair 1 |
| 0 1 0      | select control word pair 2 |
| 0 1 1      | select control word pair 3 |
| 1 0 0      | select control word pair 4 |
| 1 0 1      | select control word pair 5 |
| 1 1 0      | DO NOT descramble          |
| 1 1 1      | DO NOT descramble          |

# DVB compliant descrambler

# SAA7206H

## 7.4 Microcontroller interface

The microcontroller interface provides a means of communication between a system controller (for instance "Philips 90CE201") in a digital TV receiver and the descrambler internal registers and buffers. The physical interface consists of:

- DAT7 to DAT0; an 8-bit wide bidirectional data bus. Data and address information are multiplexed on this bus.
- $\overline{DCS}$ ; an active LOW chip select signal. The descrambler only responds to microcontroller communication if this signal is driven LOW.
- $R/\overline{W}$ ; an active HIGH read signal, indicating that the microcontroller is attempting to read data from registers or buffers inside the descrambler. If this signal is LOW, data is being written to registers or buffers inside the descrambler.
- A1 and A0; a 2-bit address bus. If the least significant address bit (0) is logic 0, the most significant byte of a 16-bit register is addressed, otherwise the least significant byte is selected. If the most significant address bit (1) is logic 1 DAT7 to DAT0 carries the address information, otherwise it will carry control data.
- $\overline{IRQ}$ ; an active LOW (open-drain output) interrupt request signal. An interrupt is set if one of the 15 bits in the descramblers internal interrupt register is set. The interrupt mechanism consists of three 15-bit registers and one 4-bit register, as illustrated in Fig.8. The interrupt status register enables the microcontroller to monitor the momentary status of the interrupts. This is particularly useful during read operations in the descramblers CA buffers, as the interrupt status bits in question ['flt0\_stat', 'flt1\_stat', etc. (see Table 10, addresses 0x0002 and 0x0004)] are reset when the buffers have been emptied or released.

The interrupt mask register (see Table 10, address 0x0001) prevents individual interrupts from resetting  $\overline{IRQ}$  (to logic 0). The interrupt status bits are logically ANDed with the mask. If a rising edge occurs on one of the resulting signals, it is latched into the interrupt register, thus resetting  $\overline{IRQ}$ .

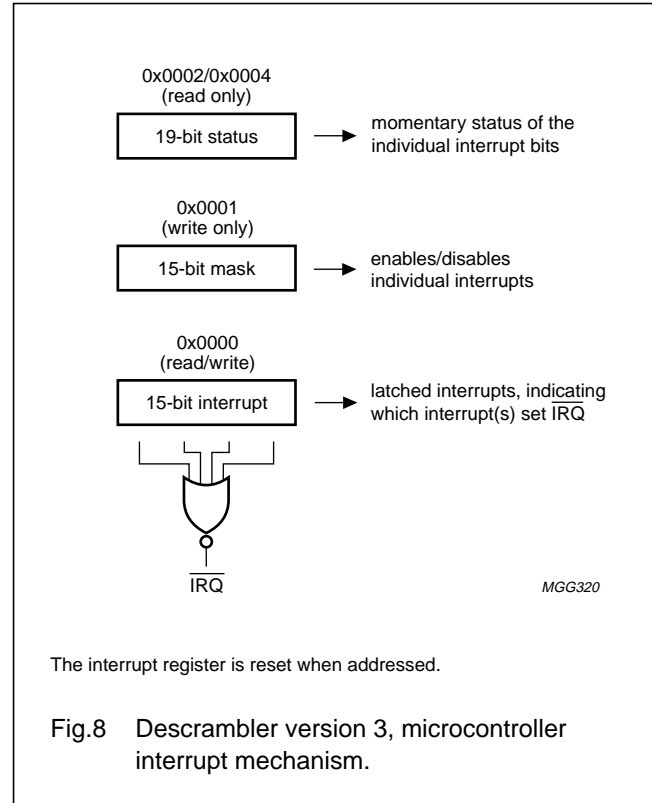

Fig.8 Descrambler version 3, microcontroller interrupt mechanism.

Table 6 Definition of interrupt mechanism; see Fig.8

| BIT NUMBER | MEANING OF INTERRUPT                      |
|------------|---|
| 0          | filter 0 retrieved CA data                |
| 1          | filter 1 retrieved CA data                |
| 2          | filter 2 retrieved CA data                |
| 3          | filter 3 retrieved CA data                |
| 4          | filter 4 retrieved CA data                |
| 5          | filter 5 retrieved CA data                |
| 6          | filter 6 retrieved CA data                |
| 7          | filter 7 retrieved CA data                |
| 8          | filter 8 retrieved CA data                |
| 9          | filter 9 retrieved CA data                |
| 10         | filter 10 retrieved CA data               |
| 11         | filter 11 retrieved CA data               |
| 12         | filter 12 retrieved CA data               |
| 13         | filter 13 retrieved CA data               |
| 14         | filter 14, 15, 16 or 17 retrieved CA data |
| 15         | empty                                     |

# DVB compliant descrambler

# SAA7206H

The interrupt register itself is reset (to 0000000000000000) as soon as it is addressed (0x0000) by the microcontroller.

A typical example of communication between microcontroller and descrambler is illustrated in Fig.9. The descrambler contains an auto increment address counter which can be loaded by performing a write address operation. The present operation, whether read or write, is now performed on the current address. The next operation, whether read or write, is performed on the current address plus 1.

**Remark:** Avoid resetting the auto increment address counter to 0x0000, when not handling interrupts, as addressing it causes the interrupt register to be reset. Consequently, interrupt information might be lost.

The descrambler internal register and buffer addresses are organized as illustrated in Fig.10. The first 4 address bits (15 to 12) are used to select either the descrambler registers (equals 0) or one of the descrambler buffers (ranges 1 and 2).

In the buffer mode, the remaining address bits (11 to 0) are part of the word address (range depending on the buffer, see Table 10). In the register mode, bits 11 to 8 specify the register unit number (see Fig.10). The remaining 8 bits of the address (7 to 0) indicate specific register addresses within a selected unit. The address range in a specific register unit depends on the number of registers present and is different for each unit. For details refer to Table 10.

The CA filter module in the microcontroller interface unit is capable of accessing general CA messages (ECM and EMM, etc.) in the transport stream. The CA filter module consists of 18 filters and 18 buffers of 256 bytes each, thus each filter has its own data buffer. The 18 filters are divided into two types of filters, which are specified in Table 9. For each filter the 'table\_id' of the section (the first byte of the section see Fig.9), can be masked.

The architecture of the 9 CA filter pairs is shown in Fig.11.

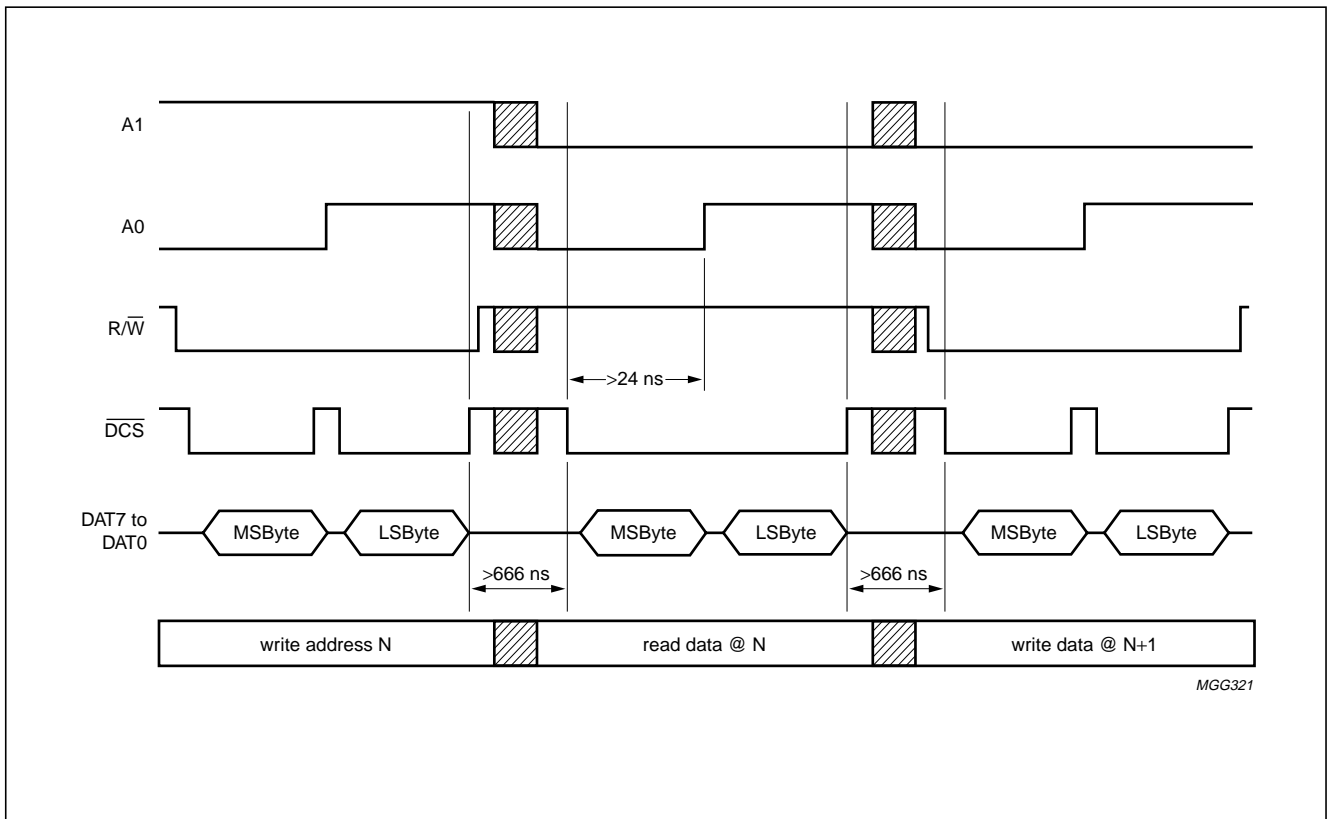

MGG321

The descrambler internal register address is incremented automatically.

Fig.9 Microcontroller descrambler communication (example).



DVB compliant descrambler

SAA7206H

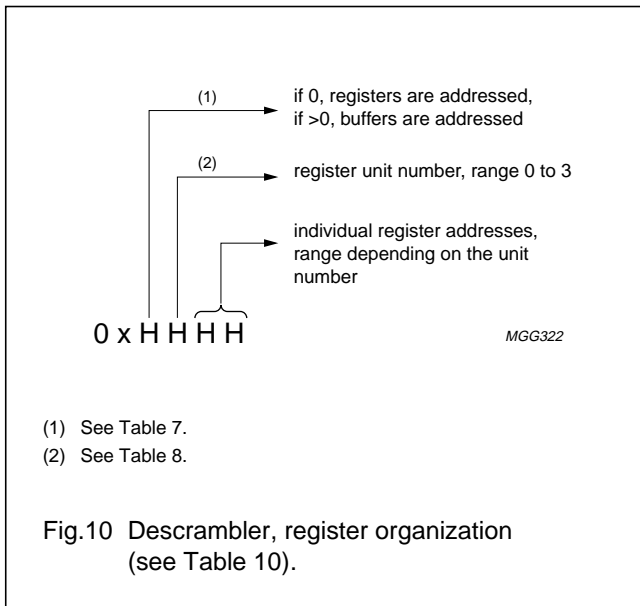

Table 7 Buffer contents

| BUFFER NUMBER | BUFFER CONTENTS                       |
|---------------|---------------------------------------|
| 1             | CW bank                               |
| 2             | CA data buffers for filters 0 to 15   |
| 3             | CA data buffers for filters 16 and 17 |

Table 8 Unit contents

| REGISTER UNIT NUMBER | UNIT CONTENTS                      |
|----------------------|------------------------------------|
| 0                    | interrupt request handling control |
| 1                    | parser input control               |
| 2                    | PID filter bank control            |
| 3                    | CA filtering control               |

Table 9 Specification of the number of CA\_data\_bytes which can be used for address filtering in the three types of filters in the CA filter module (all bits in the filter can be masked individually)

| FILTER NUMBER                     | NUMBER OF FILTERS | FILTER LENGTH (BYTES) | PID MASKABLE |
|-----------------------------------|-------------------|-----------------------|--------------|
| Filters 0 to 15                   | 16                | 7                     | no           |
| Filters 16 and 17 (DVB compliant) | 2                 | 17                    | yes          |

The filter consists of 18 section detectors. Each section detector selects and retrieves section data for CA\_messages on the basis of:

- PID; which is maskable only for filters 16 and 17
- Table\_id; which is maskable for all filters
- For filters 0 to 15; the first 7 bytes in the section payload, which are maskable for all filters (see Fig.4)
- For filters 16 and 17; the first 17 bytes in the section payload, which are maskable
- For all filters (see Fig.4).

The CA data detected by a certain filter is stored in the 256 byte buffer, only if its buffer is empty. As soon as an entire section of CA data is stored, an interrupt is generated (see Table 10, address 0x0000).

The 18 section detectors can be separately enabled, to avoid unnecessary interrupts. The 'filter fired' registers enable the microcontroller to track which filter caused a buffer to be loaded (see Table 10, addresses 0x0300 and 0x0301).

The maximum section length of a conditional access message is 256 bytes. If the section length of a message is higher, data acquisition into the buffer is stopped after 256 bytes and an interrupt signal (plus filter fired signal) is generated as normal. In this (erroneous) situation the 'section\_to\_long' bit of the filter is also set, which can be read by the microcontroller (see Table 10).

The CA filters allow retrieval of multiple consecutive CA messages, even if these messages have identical selection criteria. For this purpose the 18 filters are grouped in 9 filter pairs (0 and 1, 2 and 3 to 16 and 17). Each of the CA filters in a pair can be programmed equivalently. To prevent two filters from firing at the same time the 'equal conditions' bits of the appropriate filter pair can be programmed to logic 1. As a result, the filter with the even (equals lowest) index number (for instance filter\_8 of filter pair 8 and 9) fires at the first occurrence of a matching section. If, at the time of the second occurrence of a matching section, the buffer of the filter with the even index number is still occupied, the other filter (with odd index number) of a filter pair fires, thus storing the section data in its buffer.

## DVB compliant descrambler

## SAA7206H

If the microcontroller decides to read data from one of the CA buffers (see Table 10, address range filter\_0: 0x2000 to 0x207F to filter\_17: 0x2880 to 0x28FF) it can determine when to stop reading in two ways. It can periodically poll the 'flt0\_stat' to 'flt17\_stat' bits in the interrupt status register (see Table 10, address 0x0002 and 0x0004). Each of these bits goes LOW as soon as the last valid section data is read from the associated CA buffer.

Another possibility is to read the 'high\_flt\_address' word ('haddr7 to 0', Table 10, addresses 0x0302 to 0x0313). The high address indicates the number of valid section words (1 word = 2 bytes) that were written into the buffer. This number equals the number of read cycles that has to be performed to retrieve all valid data from the buffer.

If the buffer contents have to be removed without being read, the microcontroller can write a logic 1 to the 'rst\_bf17-0' bit (see Table 10, address 0x0314 and 0x0315) thus releasing the buffer. Another possibility is to perform a write address operation with a value of haddr7 to haddr0 plus buffer base address. The internal auto increment address counter is thus set to the last word in the buffer, causing the interrupt status bit to be reset and the filters to be reactivated, after having been idle during buffer emptying.

If, during the acquisition of a CA message, one of the TS packets composing a message contains an error ('transport\_error\_indicator' = '1') the erroneous TS packet is removed and CA message acquisition is restarted. Thus the complete CA message is lost when at least one of the TS packets which composes this message contains an error. Duplicate TS packets containing CA messages are also removed.

### 7.5 Output interfacing

The output data stream consists of a sequence of bytes. A new byte is present at the data output pins DATO7 to DATO0 at each rising edge of the descrambler chip clock DCLK. The control signals SYNCO and DVO are a delayed (9 MHz) version of the input interface signals MSYNC and MDV respectively. By this form of delay correction the relationship between the data and control signals is maintained.

The  $\overline{\text{MB}}/\text{MB}$  and MBCLK signals are not output to the demultiplexer. The descrambler converts the  $\overline{\text{MB}}/\text{MB}$  signal to the transport\_error\_indicator bit in the TS packets. At the descrambler output all information is consequently contained in the stream. MBCLK is only used to clock data into the descrambler, interfacing to the demultiplexer is performed using the 9 MHz DCLK, which is generated by the demultiplexer.

### 7.6 Boundary scan test

The DVB compliant descrambler is equipped with a 5-pins test port interface for Boundary Scan Test (BST). The implementation is in accordance with the BST standard.

DVB compliant descrambler

SAA7206H

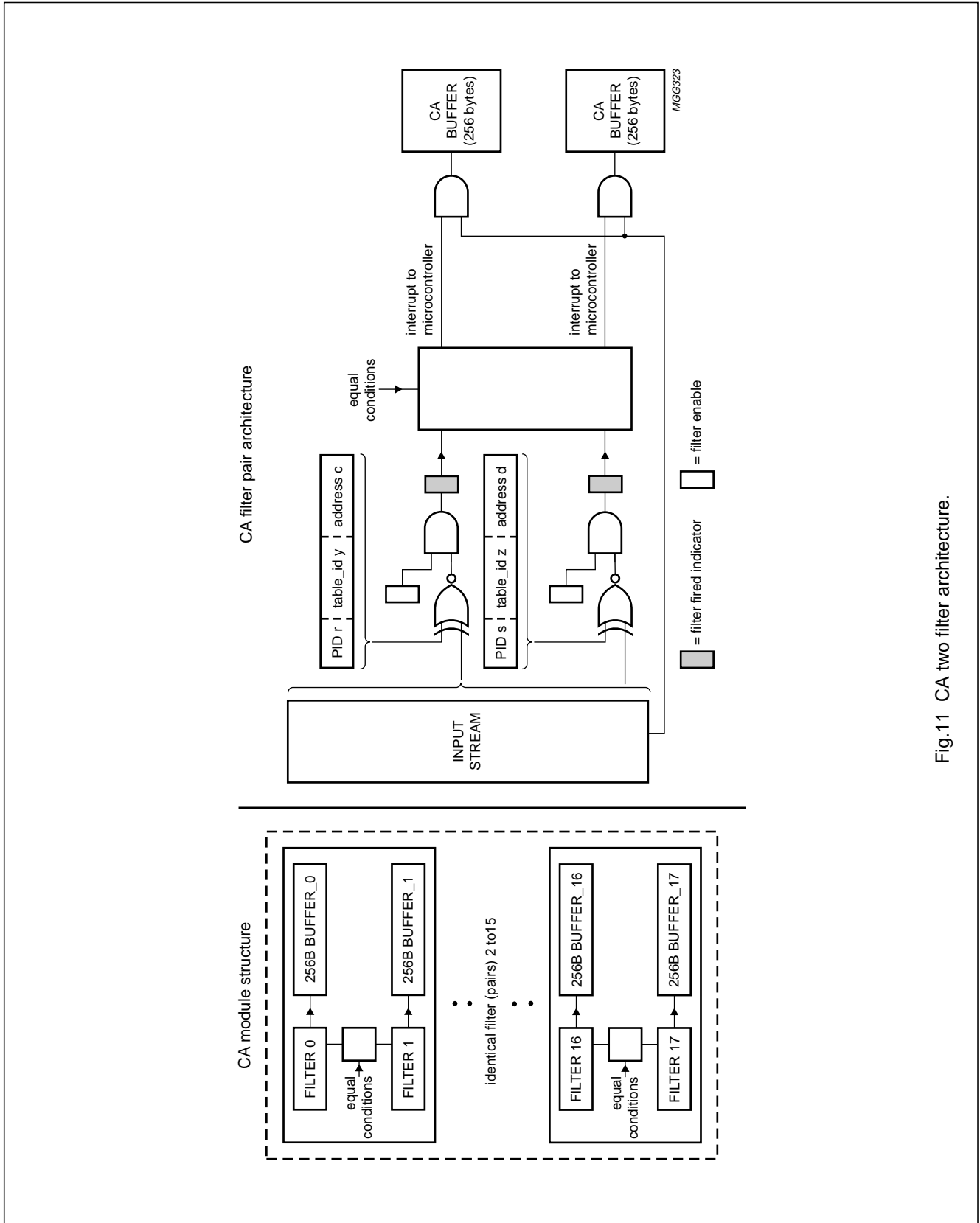

Fig.11 CA two filter architecture.

## DVB compliant descrambler

## SAA7206H

## 7.7 Programming the descrambler

Table 10 Descrambler programming.

| REGISTER FUNCTION    | ADDRESS (HEX)    | BITS      |               |            |            |            |            |              |                 |
|----------------------|------------------|-----------|---------------|------------|------------|------------|------------|--------------|-----------------|
|                      |                  | 15/7      | 14/6          | 13/5       | 12/4       | 11/3       | 10/2       | 9/1          | 8/0             |
| IRPT                 | 0x0000- R/W      |           | flt14-17_irp  | flt13_irp  | flt12_irp  | flt11_irp  | flt10_irp  | flt9_irp     | flt8_irp        |
|                      |                  | flt7_irp  | flt6_irp      | flt5_irp   | flt4_irp   | flt3_irp   | flt2_irp   | flt1_irpt    | flt0_irpt       |
| IRPT_MASK            | 0x0001- R/W      | –         | msk14         | msk13      | msk12      | msk11      | msk10      | msk9         | msk8            |
|                      |                  | msk7      | msk6          | msk5       | msk4       | msk3       | msk2       | msk1         | msk0            |
| IRPT_STATUS          | 0x0002- R        | –         | flt14-17_stat | flt13_stat | flt12_stat | flt11_stat | flt10_stat | flt9_stat    | flt8_stat       |
|                      |                  | flt7_stat | flt6_stat     | flt5_stat  | flt4_stat  | flt3_stat  | flt2_stat  | flt1_stat    | flt0_stat       |
| CHIP IDENTIFICATION  | 0x0003- R        | –         | –             | –          | –          | –          | –          | –            | –               |
|                      |                  | 0         | 0             | 0          | 0          | 0          | 0          | 1            | 1               |
| IRPT_STATUS_FLT14-17 | 0x0004- R        | –         | –             | –          | –          | –          | –          | –            | –               |
|                      |                  | –         | –             | –          | –          | flt17_stat | flt16_stat | flt15_stat   | flt14_stat      |
| EMPTY                | 0x0005 to 0x00FF | –         | –             | –          | –          | –          | –          | –            | –               |
|                      |                  | –         | –             | –          | –          | –          | –          | –            | –               |
| PRS_INP CTRL         | 0x0100- W        | –         | –             | –          | –          | –          | –          | –            | –               |
|                      |                  | –         | –             | –          | –          | –          | –          | bad_polarity | 9 MHz_interface |
| EMPTY                | 0x0101 to 0x01FF | –         | –             | –          | –          | –          | –          | –            | –               |
|                      |                  | –         | –             | –          | –          | –          | –          | –            | –               |
| PID0, CWPI0          | 0x0200- W        | pid12     | pid11         | pid10      | pid9       | pid8       | pid7       | pid6         | pid5            |
|                      |                  | pid4      | pid3          | pid2       | pid1       | pid0       | cwpi2      | cwpi1        | cwpi0           |
| PID1, CWPI1          | 0x0201- W        | pid12     | pid11         | pid10      | pid9       | pid8       | pid7       | pid6         | pid5            |
|                      |                  | pid4      | pid3          | pid2       | pid1       | pid0       | cwpi2      | cwpi1        | cwpi0           |
| PID2, CWPI2          | 0x0202- W        | pid12     | pid11         | pid10      | pid9       | pid8       | pid7       | pid6         | pid5            |
|                      |                  | pid4      | pid3          | pid2       | pid1       | pid0       | cwpi2      | cwpi1        | cwpi0           |
| PID3, CWPI3          | 0x0203- W        | pid12     | pid11         | pid10      | pid9       | pid8       | pid7       | pid6         | pid5            |
|                      |                  | pid4      | pid3          | pid2       | pid1       | pid0       | cwpi2      | cwpi1        | cwpi0           |
| PID4, CWPI4          | 0x0204- W        | pid12     | pid11         | pid10      | pid9       | pid8       | pid7       | pid6         | pid5            |
|                      |                  | pid4      | pid3          | pid2       | pid1       | pid0       | cwpi2      | cwpi1        | cwpi0           |
| PID5, CWPI5          | 0x0205- W        | pid12     | pid11         | pid10      | pid9       | pid8       | pid7       | pid6         | pid5            |
|                      |                  | pid4      | pid3          | pid2       | pid1       | pid0       | cwpi2      | cwpi1        | cwpi0           |

## DVB compliant descrambler

SAA7206H

| REGISTER FUNCTION     | ADDRESS (HEX)          | BITS            |               |               |               |               |               |               |               |
|-----------------------|------------------------|-----------------|---------------|---------------|---------------|---------------|---------------|---------------|---------------|
|                       |                        | 15/7            | 14/6          | 13/5          | 12/4          | 11/3          | 10/2          | 9/1           | 8/0           |
| DCW_VALID             | 0x0206- $\overline{W}$ | –               | –             | –             | –             | –             | –             | –             | –             |
|                       |                        | –               | PID5_is_pes   | PID4_is_pes   | PID3_is_pes   | PID2_is_pes   | PID1_is_pes   | PID0_is_pes   | DCW_valid     |
| TS_SCR_CTRL           | 0x0207- R              | –               | –             | –             | –             | ts_sc_pid5_1  | ts_sc_pid5_0  | ts_sc_pid4_1  | ts_sc_pid4_0  |
|                       |                        | ts_sc_pid3_1    | ts_sc_pid3_0  | ts_sc_pid2_1  | ts_sc_pid2_0  | ts_sc_pid1_1  | ts_sc_pid1_0  | ts_sc_pid0_1  | ts_sc_pid0_0  |
| PES_SCR_CTRL          | 0x0208- R              | –               | –             | –             | –             | pes_sc_pid5_1 | pes_sc_pid5_0 | pes_sc_pid4_1 | pes_sc_pid4_0 |
|                       |                        | pes_sc_pid3_1   | pes_sc_pid3_0 | pes_sc_pid2_1 | pes_sc_pid2_0 | pes_sc_pid1_1 | pes_sc_pid1_0 | pes_sc_pid0_1 | pes_sc_pid0_0 |
| PID5_MASK             | 0x0209- $\overline{W}$ | –               | –             | –             | pid5_msk12    | pid5_msk11    | pid5_msk10    | pid5_msk9     | pid5_msk8     |
|                       |                        | pid5_msk7       | pid5_msk6     | pid5_msk5     | pid5_msk4     | pid5_msk3     | pid5_msk2     | pid5_msk1     | pid5_msk0     |
| EMPTY                 | 0x0210 to 0x02FF       | –               | –             | –             | –             | –             | –             | –             | –             |
|                       |                        | –               | –             | –             | –             | –             | –             | –             | –             |
| FLT17-16 FIRED STATUS | 0x0300- R              | –               | –             | –             | –             | –             | –             | –             | –             |
|                       |                        | –               | –             | –             | –             | –             | –             | flt17_frd     | flt16_frd     |
| FLT15-0 FIRED STATUS  | 0x0301- R              | flt15_frd       | flt14_frd     | flt13_frd     | flt12_frd     | flt11_frd     | flt10_frd     | flt9_frd      | flt8_frd      |
|                       |                        | flt7_frd        | flt6_frd      | flt5_frd      | flt4_frd      | flt3_frd      | flt2_frd      | flt1_frd      | flt0_frd      |
| FLT0 STATUS           | 0x0302- R              | section to_long | –             | –             | –             | –             | –             | –             | –             |
|                       |                        | hadr0_7         | hadr0_6       | hadr0_5       | hadr0_4       | hadr0_3       | hadr0_2       | hadr0_1       | hadr0_0       |
| FLT1 STATUS           | 0x0303- R              | section to_long | –             | –             | –             | –             | –             | –             | –             |
|                       |                        | hadr1_7         | hadr1_6       | hadr1_5       | hadr1_4       | hadr1_3       | hadr1_2       | hadr1_1       | hadr1_0       |
| FLT2 STATUS           | 0x0304- R              | section to_long | –             | –             | –             | –             | –             | –             | –             |
|                       |                        | hadr2_7         | hadr2_6       | hadr2_5       | hadr2_4       | hadr2_3       | hadr2_2       | hadr2_1       | hadr2_0       |
| FLT3 STATUS           | 0x0305- R              | section to_long | –             | –             | –             | –             | –             | –             | –             |
|                       |                        | hadr3_7         | hadr3_6       | hadr3_5       | hadr3_4       | hadr3_3       | hadr3_2       | hadr3_1       | hadr3_0       |

## DVB compliant descrambler

SAA7206H

| REGISTER<br>FUNCTION | ADDRESS<br>(HEX) | BITS               |          |          |          |          |          |          |          |
|----------------------|------------------|--------------------|----------|----------|----------|----------|----------|----------|----------|
|                      |                  | 15/7               | 14/6     | 13/5     | 12/4     | 11/3     | 10/2     | 9/1      | 8/0      |
| FLT4 STATUS          | 0x0306- R        | section<br>to_long | –        | –        | –        | –        | –        | –        | –        |
|                      |                  | hadr4_7            | hadr4_6  | hadr4_5  | hadr4_4  | hadr4_3  | hadr4_2  | hadr4_1  | hadr4_0  |
| FLT5 STATUS          | 0x0307- R        | section<br>to_long | –        | –        | –        | –        | –        | –        | –        |
|                      |                  | hadr5_7            | hadr5_6  | hadr5_5  | hadr5_4  | hadr5_3  | hadr5_2  | hadr5_1  | hadr5_0  |
| FLT6 STATUS          | 0x0308- R        | section<br>to_long | –        | –        | –        | –        | –        | –        | –        |
|                      |                  | hadr6_7            | hadr6_6  | hadr6_5  | hadr6_4  | hadr6_3  | hadr6_2  | hadr6_1  | hadr6_0  |
| FLT7 STATUS          | 0x0309- R        | section<br>to_long | –        | –        | –        | –        | –        | –        | –        |
|                      |                  | hadr7_7            | hadr7_6  | hadr7_5  | hadr7_4  | hadr7_3  | hadr7_2  | hadr7_1  | hadr7_0  |
| FLT8 STATUS          | 0x030A- R        | section<br>to_long | –        | –        | –        | –        | –        | –        | –        |
|                      |                  | hadr8_7            | hadr8_6  | hadr8_5  | hadr8_4  | hadr8_3  | hadr8_2  | hadr8_1  | hadr8_0  |
| FLT9 STATUS          | 0x030B- R        | section<br>to_long | –        | –        | –        | –        | –        | –        | –        |
|                      |                  | hadr9_7            | hadr9_6  | hadr9_5  | hadr9_4  | hadr9_3  | hadr9_2  | hadr9_1  | hadr9_0  |
| FLT10 STATUS         | 0x030C- R        | section<br>to_long | –        | –        | –        | –        | –        | –        | –        |
|                      |                  | hadr10_7           | hadr10_6 | hadr10_5 | hadr10_4 | hadr10_3 | hadr10_2 | hadr10_1 | hadr10_0 |
| FLT11 STATUS         | 0x030D- R        | section<br>to_long | –        | –        | –        | –        | –        | –        | –        |
|                      |                  | hadr11_7           | hadr11_6 | hadr11_5 | hadr11_4 | hadr11_3 | hadr11_2 | hadr11_1 | hadr11_0 |
| FLT12 STATUS         | 0x030E- R        | section<br>to_long | –        | –        | –        | –        | –        | –        | –        |
|                      |                  | hadr12_7           | hadr12_6 | hadr12_5 | hadr12_4 | hadr12_3 | hadr12_2 | hadr12_1 | hadr12_0 |
| FLT13 STATUS         | 0x030F- R        | section<br>to_long | –        | –        | –        | –        | –        | –        | –        |
|                      |                  | hadr13_7           | hadr13_6 | hadr13_5 | hadr13_4 | hadr13_3 | hadr13_2 | hadr13_1 | hadr13_0 |

## DVB compliant descrambler

SAA7206H

| REGISTER<br>FUNCTION      | ADDRESS<br>(HEX)  | BITS               |            |          |          |          |          |          |          |
|---------------------------|-------------------|--------------------|------------|----------|----------|----------|----------|----------|----------|
|                           |                   | 15/7               | 14/6       | 13/5     | 12/4     | 11/3     | 10/2     | 9/1      | 8/0      |
| FLT14 STATUS              | 0x0310- R         | section<br>to_long | –          | –        | –        | –        | –        | –        | –        |
|                           |                   | hadr14_7           | hadr14_6   | hadr14_5 | hadr14_4 | hadr14_3 | hadr14_2 | hadr14_1 | hadr14_0 |
| FLT15 STATUS              | 0x0311- R         | section<br>to_long | –          | –        | –        | –        | –        | –        | –        |
|                           |                   | hadr15_7           | hadr15_6   | hadr15_5 | hadr15_4 | hadr15_3 | hadr15_2 | hadr15_1 | hadr15_0 |
| FLT16 STATUS              | 0x0312- R         | section<br>to_long | –          | –        | –        | –        | –        | –        | –        |
|                           |                   | hadr16_7           | hadr16_6   | hadr16_5 | hadr16_4 | hadr16_3 | hadr16_2 | hadr16_1 | hadr16_0 |
| FLT17 STATUS              | 0x0313- R         | section<br>to_long | –          | –        | –        | –        | –        | –        | –        |
|                           |                   | hadr17_7           | hadr17_6   | hadr17_5 | hadr17_4 | hadr17_3 | hadr17_2 | hadr17_1 | hadr17_0 |
| RESET BUFFER<br>16 and 17 | 0x0314- $\bar{W}$ | –                  | –          | –        | –        | –        | –        | –        | –        |
|                           |                   | –                  | –          | –        | –        | –        | –        | rst_bf17 | rst_bf16 |
| RESET BUFFER<br>0 to 15   | 0x0315- $\bar{W}$ | rst_bf15           | rst_bf14   | rst_bf13 | rst_bf12 | rst_bf11 | rst_bf10 | rst_bf9  | rst_bf8  |
|                           |                   | rst_bf7            | rst_bf6    | rst_bf5  | rst_bf4  | rst_bf3  | rst_bf2  | rst_bf1  | rst_bf0  |
| FLT0 CNTRL                | 0x0316- $\bar{W}$ | –                  | equal_cond | enable   | pid12    | pid11    | pid10    | pid9     | pid8     |
|                           |                   | pid7               | pid6       | pid5     | pid4     | pid3     | pid2     | pid1     | pid0     |
| FLT0 TBL_ID               | 0x0317- $\bar{W}$ | msk7               | msk6       | msk5     | msk4     | msk3     | msk2     | msk1     | msk0     |
|                           |                   | tblid_7            | tblid_6    | tblid_5  | tblid_4  | tblid_3  | tblid_2  | tblid_1  | tblid_0  |
| FLT0 ADR BYTE0            | 0x0318- $\bar{W}$ | msk7               | msk6       | msk5     | msk4     | msk3     | msk2     | msk1     | msk0     |
|                           |                   | adr7               | adr6       | adr5     | adr4     | adr3     | adr2     | adr1     | adr0     |
| FLT0 ADR BYTE1            | 0x0319- W         | msk7               | msk6       | msk5     | msk4     | msk3     | msk2     | msk1     | msk0     |
|                           |                   | adr7               | adr6       | adr5     | adr4     | adr3     | adr2     | adr1     | adr0     |
| FLT0 ADR BYTE2            | 0x031A- W         | msk7               | msk6       | msk5     | msk4     | msk3     | msk2     | msk1     | msk0     |
|                           |                   | adr7               | adr6       | adr5     | adr4     | adr3     | adr2     | adr1     | adr0     |
| FLT0 ADR BYTE3            | 0x031B- $\bar{W}$ | msk7               | msk6       | msk5     | msk4     | msk3     | msk2     | msk1     | msk0     |
|                           |                   | adr7               | adr6       | adr5     | adr4     | adr3     | adr2     | adr1     | adr0     |
| FLT0 ADR BYTE4            | 0x031C- $\bar{W}$ | msk7               | msk6       | msk5     | msk4     | msk3     | msk2     | msk1     | msk0     |
|                           |                   | adr7               | adr6       | adr5     | adr4     | adr3     | adr2     | adr1     | adr0     |

## DVB compliant descrambler

SAA7206H

| REGISTER<br>FUNCTION | ADDRESS<br>(HEX)  | BITS    |            |         |         |         |         |         |         |
|----------------------|-------------------|---------|------------|---------|---------|---------|---------|---------|---------|
|                      |                   | 15/7    | 14/6       | 13/5    | 12/4    | 11/3    | 10/2    | 9/1     | 8/0     |
| FLT0 ADR BYTE5       | 0x031D- $\bar{W}$ | msk7    | msk6       | msk5    | msk4    | msk3    | msk2    | msk1    | msk0    |
|                      |                   | adr7    | adr6       | adr5    | adr4    | adr3    | adr2    | adr1    | adr0    |
| FLT0 ADR BYTE6       | 0x031E- $\bar{W}$ | msk7    | msk6       | msk5    | msk4    | msk3    | msk2    | msk1    | msk0    |
|                      |                   | adr7    | adr6       | adr5    | adr4    | adr3    | adr2    | adr1    | adr0    |
| FLT1 CNTRL           | 0x031F- $\bar{W}$ | –       | equal_cond | enable  | pid12   | pid11   | pid10   | pid9    | pid8    |
|                      |                   | pid7    | pid6       | pid5    | pid4    | pid3    | pid2    | pid1    | pid0    |
| FLT1 TBL_ID          | 0x0320- $\bar{W}$ | msk7    | msk6       | msk5    | msk4    | msk3    | msk2    | msk1    | msk0    |
|                      |                   | tblid_7 | tblid_6    | tblid_5 | tblid_4 | tblid_3 | tblid_2 | tblid_1 | tblid_0 |
| FLT1 ADR BYTE0       | 0x0321- $\bar{W}$ | msk7    | msk6       | msk5    | msk4    | msk3    | msk2    | msk1    | msk0    |
|                      |                   | adr7    | adr6       | adr5    | adr4    | adr3    | adr2    | adr1    | adr0    |
| FLT1 ADR BYTE1       | 0x0322- $\bar{W}$ | msk7    | msk6       | msk5    | msk4    | msk3    | msk2    | msk1    | msk0    |
|                      |                   | adr7    | adr6       | adr5    | adr4    | adr3    | adr2    | adr1    | adr0    |
| FLT1 ADR BYTE2       | 0x0323- $\bar{W}$ | msk7    | msk6       | msk5    | msk4    | msk3    | msk2    | msk1    | msk0    |
|                      |                   | adr7    | adr6       | adr5    | adr4    | adr3    | adr2    | adr1    | adr0    |
| FLT1 ADR BYTE3       | 0x0324- $\bar{W}$ | msk7    | msk6       | msk5    | msk4    | msk3    | msk2    | msk1    | msk0    |
|                      |                   | adr7    | adr6       | adr5    | adr4    | adr3    | adr2    | adr1    | adr0    |
| FLT1 ADR BYTE4       | 0x0325- $\bar{W}$ | msk7    | msk6       | msk5    | msk4    | msk3    | msk2    | msk1    | msk0    |
|                      |                   | adr7    | adr6       | adr5    | adr4    | adr3    | adr2    | adr1    | adr0    |
| FLT1 ADR BYTE5       | 0x0326- $\bar{W}$ | msk7    | msk6       | msk5    | msk4    | msk3    | msk2    | msk1    | msk0    |
|                      |                   | adr7    | adr6       | adr5    | adr4    | adr3    | adr2    | adr1    | adr0    |
| FLT1 ADR BYTE6       | 0x0327- $\bar{W}$ | msk7    | msk6       | msk5    | msk4    | msk3    | msk2    | msk1    | msk0    |
|                      |                   | adr7    | adr6       | adr5    | adr4    | adr3    | adr2    | adr1    | adr0    |
| FLT2 CNTRL           | 0x0328- $\bar{W}$ | –       | equal_cond | enable  | pid12   | pid11   | pid10   | pid9    | pid8    |
|                      |                   | pid7    | pid6       | pid5    | pid4    | pid3    | pid2    | pid1    | pid0    |
| FLT2 TBL_ID          | 0x0329- $\bar{W}$ | msk7    | msk6       | msk5    | msk4    | msk3    | msk2    | msk1    | msk0    |
|                      |                   | tblid_7 | tblid_6    | tblid_5 | tblid_4 | tblid_3 | tblid_2 | tblid_1 | tblid_0 |
| FLT2 ADR BYTE0       | 0x032A- $\bar{W}$ | msk7    | msk6       | msk5    | msk4    | msk3    | msk2    | msk1    | msk0    |
|                      |                   | adr7    | adr6       | adr5    | adr4    | adr3    | adr2    | adr1    | adr0    |
| FLT2 ADR BYTE1       | 0x032B- $\bar{W}$ | msk7    | msk6       | msk5    | msk4    | msk3    | msk2    | msk1    | msk0    |
|                      |                   | adr7    | adr6       | adr5    | adr4    | adr3    | adr2    | adr1    | adr0    |



## DVB compliant descrambler

SAA7206H

| REGISTER<br>FUNCTION | ADDRESS<br>(HEX)  | BITS    |            |         |         |         |         |         |         |
|----------------------|-------------------|---------|------------|---------|---------|---------|---------|---------|---------|
|                      |                   | 15/7    | 14/6       | 13/5    | 12/4    | 11/3    | 10/2    | 9/1     | 8/0     |
| FLT2 ADR BYTE2       | 0x032C- $\bar{W}$ | msk7    | msk6       | msk5    | msk4    | msk3    | msk2    | msk1    | msk0    |
|                      |                   | adr7    | adr6       | adr5    | adr4    | adr3    | adr2    | adr1    | adr0    |
| FLT2 ADR BYTE3       | 0x032D- $\bar{W}$ | msk7    | msk6       | msk5    | msk4    | msk3    | msk2    | msk1    | msk0    |
|                      |                   | adr7    | adr6       | adr5    | adr4    | adr3    | adr2    | adr1    | adr0    |
| FLT2 ADR BYTE4       | 0x032E- $\bar{W}$ | msk7    | msk6       | msk5    | msk4    | msk3    | msk2    | msk1    | msk0    |
|                      |                   | adr7    | adr6       | adr5    | adr4    | adr3    | adr2    | adr1    | adr0    |
| FLT2 ADR BYTE5       | 0x032F- $\bar{W}$ | msk7    | msk6       | msk5    | msk4    | msk3    | msk2    | msk1    | msk0    |
|                      |                   | adr7    | adr6       | adr5    | adr4    | adr3    | adr2    | adr1    | adr0    |
| FLT2 ADR BYTE6       | 0x0330- $\bar{W}$ | msk7    | msk6       | msk5    | msk4    | msk3    | msk2    | msk1    | msk0    |
|                      |                   | adr7    | adr6       | adr5    | adr4    | adr3    | adr2    | adr1    | adr0    |
| FLT3 CNTRL           | 0x0331- $\bar{W}$ | –       | equal_cond | enable  | pid12   | pid11   | pid10   | pid9    | pid8    |
|                      |                   | pid7    | pid6       | pid5    | pid4    | pid3    | pid2    | pid1    | pid0    |
| FLT3 TBL_ID          | 0x0332- $\bar{W}$ | msk7    | msk6       | msk5    | msk4    | msk3    | msk2    | msk1    | msk0    |
|                      |                   | tblid_7 | tblid_6    | tblid_5 | tblid_4 | tblid_3 | tblid_2 | tblid_1 | tblid_0 |
| FLT3 ADR BYTE0       | 0x0333- $\bar{W}$ | msk7    | msk6       | msk5    | msk4    | msk3    | msk2    | msk1    | msk0    |
|                      |                   | adr7    | adr6       | adr5    | adr4    | adr3    | adr2    | adr1    | adr0    |
| FLT3 ADR BYTE1       | 0x0334- $\bar{W}$ | msk7    | msk6       | msk5    | msk4    | msk3    | msk2    | msk1    | msk0    |
|                      |                   | adr7    | adr6       | adr5    | adr4    | adr3    | adr2    | adr1    | adr0    |
| FLT3 ADR BYTE2       | 0x0335- $\bar{W}$ | msk7    | msk6       | msk5    | msk4    | msk3    | msk2    | msk1    | msk0    |
|                      |                   | adr7    | adr6       | adr5    | adr4    | adr3    | adr2    | adr1    | adr0    |
| FLT3 ADR BYTE3       | 0x0336- $\bar{W}$ | msk7    | msk6       | msk5    | msk4    | msk3    | msk2    | msk1    | msk0    |
|                      |                   | adr7    | adr6       | adr5    | adr4    | adr3    | adr2    | adr1    | adr0    |
| FLT3 ADR BYTE4       | 0x0337- $\bar{W}$ | msk7    | msk6       | msk5    | msk4    | msk3    | msk2    | msk1    | msk0    |
|                      |                   | adr7    | adr6       | adr5    | adr4    | adr3    | adr2    | adr1    | adr0    |
| FLT3 ADR BYTE5       | 0x0338- $\bar{W}$ | msk7    | msk6       | msk5    | msk4    | msk3    | msk2    | msk1    | msk0    |
|                      |                   | adr7    | adr6       | adr5    | adr4    | adr3    | adr2    | adr1    | adr0    |
| FLT3 DR BYTE6        | 0x0339- $\bar{W}$ | msk7    | msk6       | msk5    | msk4    | msk3    | msk2    | msk1    | msk0    |
|                      |                   | adr7    | adr6       | adr5    | adr4    | adr3    | adr2    | adr1    | adr0    |
| FLT4 CNTRL           | 0x033A- $\bar{W}$ | –       | equal_cond | enable  | pid12   | pid11   | pid10   | pid9    | pid8    |
|                      |                   | pid7    | pid6       | pid5    | pid4    | pid3    | pid2    | pid1    | pid0    |

## DVB compliant descrambler

SAA7206H

| REGISTER<br>FUNCTION | ADDRESS<br>(HEX)  | BITS    |            |         |         |         |         |         |         |
|----------------------|-------------------|---------|------------|---------|---------|---------|---------|---------|---------|
|                      |                   | 15/7    | 14/6       | 13/5    | 12/4    | 11/3    | 10/2    | 9/1     | 8/0     |
| FLT4 TBL_ID          | 0x033B- $\bar{W}$ | msk7    | msk6       | msk5    | msk4    | msk3    | msk2    | msk1    | msk0    |
|                      |                   | tblid_7 | tblid_6    | tblid_5 | tblid_4 | tblid_3 | tblid_2 | tblid_1 | tblid_0 |
| FLT4 ADR BYTE0       | 0x033C- $\bar{W}$ | msk7    | msk6       | msk5    | msk4    | msk3    | msk2    | msk1    | msk0    |
|                      |                   | adr7    | adr6       | adr5    | adr4    | adr3    | adr2    | adr1    | adr0    |
| FLT4 ADR BYTE1       | 0x033D- $\bar{W}$ | msk7    | msk6       | msk5    | msk4    | msk3    | msk2    | msk1    | msk0    |
|                      |                   | adr7    | adr6       | adr5    | adr4    | adr3    | adr2    | adr1    | adr0    |
| FLT4 ADR BYTE2       | 0x033E- $\bar{W}$ | msk7    | msk6       | msk5    | msk4    | msk3    | msk2    | msk1    | msk0    |
|                      |                   | adr7    | adr6       | adr5    | adr4    | adr3    | adr2    | adr1    | adr0    |
| FLT4 ADR BYTE3       | 0x033F- $\bar{W}$ | msk7    | msk6       | msk5    | msk4    | msk3    | msk2    | msk1    | msk0    |
|                      |                   | adr7    | adr6       | adr5    | adr4    | adr3    | adr2    | adr1    | adr0    |
| FLT4 ADR BYTE4       | 0x0340- $\bar{W}$ | msk7    | msk6       | msk5    | msk4    | msk3    | msk2    | msk1    | msk0    |
|                      |                   | adr7    | adr6       | adr5    | adr4    | adr3    | adr2    | adr1    | adr0    |
| FLT4 ADR BYTE5       | 0x0341- $\bar{W}$ | msk7    | msk6       | msk5    | msk4    | msk3    | msk2    | msk1    | msk0    |
|                      |                   | adr7    | adr6       | adr5    | adr4    | adr3    | adr2    | adr1    | adr0    |
| FLT4 ADR BYTE6       | 0x0342- $\bar{W}$ | msk7    | msk6       | msk5    | msk4    | msk3    | msk2    | msk1    | msk0    |
|                      |                   | adr7    | adr6       | adr5    | adr4    | adr3    | adr2    | adr1    | adr0    |
| FLT5 CNTRL           | 0x0343- $\bar{W}$ | –       | equal_cond | enable  | pid12   | pid11   | pid10   | pid9    | pid8    |
|                      |                   | pid7    | pid6       | pid5    | pid4    | pid3    | pid2    | pid1    | pid0    |
| FLT5 TBL_ID          | 0x0344- $\bar{W}$ | msk7    | msk6       | msk5    | msk4    | msk3    | msk2    | msk1    | msk0    |
|                      |                   | tblid_7 | tblid_6    | tblid_5 | tblid_4 | tblid_3 | tblid_2 | tblid_1 | tblid_0 |
| FLT5 ADR BYTE0       | 0x0345- $\bar{W}$ | msk7    | msk6       | msk5    | msk4    | msk3    | msk2    | msk1    | msk0    |
|                      |                   | adr7    | adr6       | adr5    | adr4    | adr3    | adr2    | adr1    | adr0    |
| FLT5 ADR BYTE1       | 0x0346- $\bar{W}$ | msk7    | msk6       | msk5    | msk4    | msk3    | msk2    | msk1    | msk0    |
|                      |                   | adr7    | adr6       | adr5    | adr4    | adr3    | adr2    | adr1    | adr0    |
| FLT5 ADR BYTE2       | 0x0347- W         | msk7    | msk6       | msk5    | msk4    | msk3    | msk2    | msk1    | msk0    |
|                      |                   | adr7    | adr6       | adr5    | adr4    | adr3    | adr2    | adr1    | adr0    |
| FLT5 ADR BYTE3       | 0x0348- $\bar{W}$ | msk7    | msk6       | msk5    | msk4    | msk3    | msk2    | msk1    | msk0    |
|                      |                   | adr7    | adr6       | adr5    | adr4    | adr3    | adr2    | adr1    | adr0    |
| FLT5 ADR BYTE4       | 0x0349- $\bar{W}$ | msk7    | msk6       | msk5    | msk4    | msk3    | msk2    | msk1    | msk0    |
|                      |                   | adr7    | adr6       | adr5    | adr4    | adr3    | adr2    | adr1    | adr0    |

## DVB compliant descrambler

SAA7206H

| REGISTER FUNCTION | ADDRESS (HEX)          | BITS    |            |         |         |         |         |         |         |
|-------------------|------------------------|---------|------------|---------|---------|---------|---------|---------|---------|
|                   |                        | 15/7    | 14/6       | 13/5    | 12/4    | 11/3    | 10/2    | 9/1     | 8/0     |
| FLT5 ADR BYTE5    | 0x034A- $\overline{W}$ | msk7    | msk6       | msk5    | msk4    | msk3    | msk2    | msk1    | msk0    |
|                   |                        | adr7    | adr6       | adr5    | adr4    | adr3    | adr2    | adr1    | adr0    |
| FLT5 ADR BYTE6    | 0x034B- $\overline{W}$ | msk7    | msk6       | msk5    | msk4    | msk3    | msk2    | msk1    | msk0    |
|                   |                        | adr7    | adr6       | adr5    | adr4    | adr3    | adr2    | adr1    | adr0    |
| FLT6 CNTRL        | 0x034C- $\overline{W}$ | –       | equal_cond | enable  | pid12   | pid11   | pid10   | pid9    | pid8    |
|                   |                        | pid7    | pid6       | pid5    | pid4    | pid3    | pid2    | pid1    | pid0    |
| FLT6 TBL_ID       | 0x034D- $\overline{W}$ | msk7    | msk6       | msk5    | msk4    | msk3    | msk2    | msk1    | msk0    |
|                   |                        | tblid_7 | tblid_6    | tblid_5 | tblid_4 | tblid_3 | tblid_2 | tblid_1 | tblid_0 |
| FLT6 ADR BYTE0    | 0x034E- $\overline{W}$ | msk7    | msk6       | msk5    | msk4    | msk3    | msk2    | msk1    | msk0    |
|                   |                        | adr7    | adr6       | adr5    | adr4    | adr3    | adr2    | adr1    | adr0    |
| FLT6 ADR BYTE1    | 0x034F- $\overline{W}$ | msk7    | msk6       | msk5    | msk4    | msk3    | msk2    | msk1    | msk0    |
|                   |                        | adr7    | adr6       | adr5    | adr4    | adr3    | adr2    | adr1    | adr0    |
| FLT6 ADR BYTE2    | 0x0350- $\overline{W}$ | msk7    | msk6       | msk5    | msk4    | msk3    | msk2    | msk1    | msk0    |
|                   |                        | adr7    | adr6       | adr5    | adr4    | adr3    | adr2    | adr1    | adr0    |
| FLT6 ADR BYTE3    | 0x0351- $\overline{W}$ | msk7    | msk6       | msk5    | msk4    | msk3    | msk2    | msk1    | msk0    |
|                   |                        | adr7    | adr6       | adr5    | adr4    | adr3    | adr2    | adr1    | adr0    |
| FLT6 ADR BYTE4    | 0x0352- $\overline{W}$ | msk7    | msk6       | msk5    | msk4    | msk3    | msk2    | msk1    | msk0    |
|                   |                        | adr7    | adr6       | adr5    | adr4    | adr3    | adr2    | adr1    | adr0    |
| FLT6 ADR BYTE5    | 0x0353- $\overline{W}$ | msk7    | msk6       | msk5    | msk4    | msk3    | msk2    | msk1    | msk0    |
|                   |                        | adr7    | adr6       | adr5    | adr4    | adr3    | adr2    | adr1    | adr0    |
| FLT6 ADR BYTE6    | 0x0354- $\overline{W}$ | msk7    | msk6       | msk5    | msk4    | msk3    | msk2    | msk1    | msk0    |
|                   |                        | adr7    | adr6       | adr5    | adr4    | adr3    | adr2    | adr1    | adr0    |
| FLT7 CNTRL        | 0x0355- $\overline{W}$ | –       | equal_cond | enable  | pid12   | pid11   | pid10   | pid9    | pid8    |
|                   |                        | pid7    | pid6       | pid5    | pid4    | pid3    | pid2    | pid1    | pid0    |
| FLT7 TBL_ID       | 0x0356- $\overline{W}$ | msk7    | msk6       | msk5    | msk4    | msk3    | msk2    | msk1    | msk0    |
|                   |                        | tblid_7 | tblid_6    | tblid_5 | tblid_4 | tblid_3 | tblid_2 | tblid_1 | tblid_0 |
| FLT7 ADR BYTE0    | 0x0357- $\overline{W}$ | msk7    | msk6       | msk5    | msk4    | msk3    | msk2    | msk1    | msk0    |
|                   |                        | adr7    | adr6       | adr5    | adr4    | adr3    | adr2    | adr1    | adr0    |
| FLT7 ADR BYTE1    | 0x0358- $\overline{W}$ | msk7    | msk6       | msk5    | msk4    | msk3    | msk2    | msk1    | msk0    |
|                   |                        | adr7    | adr6       | adr5    | adr4    | adr3    | adr2    | adr1    | adr0    |

## DVB compliant descrambler

SAA7206H

| REGISTER FUNCTION | ADDRESS (HEX)          | BITS    |            |         |         |         |         |         |         |
|-------------------|------------------------|---------|------------|---------|---------|---------|---------|---------|---------|
|                   |                        | 15/7    | 14/6       | 13/5    | 12/4    | 11/3    | 10/2    | 9/1     | 8/0     |
| FLT7 ADR BYTE2    | 0x0359- $\overline{W}$ | msk7    | msk6       | msk5    | msk4    | msk3    | msk2    | msk1    | msk0    |
|                   |                        | adr7    | adr6       | adr5    | adr4    | adr3    | adr2    | adr1    | adr0    |
| FLT7 ADR BYTE3    | 0x035A- $\overline{W}$ | msk7    | msk6       | msk5    | msk4    | msk3    | msk2    | msk1    | msk0    |
|                   |                        | adr7    | adr6       | adr5    | adr4    | adr3    | adr2    | adr1    | adr0    |
| FLT7 ADR BYTE4    | 0x035B- $\overline{W}$ | msk7    | msk6       | msk5    | msk4    | msk3    | msk2    | msk1    | msk0    |
|                   |                        | adr7    | adr6       | adr5    | adr4    | adr3    | adr2    | adr1    | adr0    |
| FLT7 ADR BYTE5    | 0x035C- $\overline{W}$ | msk7    | msk6       | msk5    | msk4    | msk3    | msk2    | msk1    | msk0    |
|                   |                        | adr7    | adr6       | adr5    | adr4    | adr3    | adr2    | adr1    | adr0    |
| FLT7 ADR BYTE6    | 0x035D- $\overline{W}$ | msk7    | msk6       | msk5    | msk4    | msk3    | msk2    | msk1    | msk0    |
|                   |                        | adr7    | adr6       | adr5    | adr4    | adr3    | adr2    | adr1    | adr0    |
| FLT8 CNTRL        | 0x035E- $\overline{W}$ | –       | equal_cond | enable  | pid12   | pid11   | pid10   | pid9    | pid8    |
|                   |                        | pid7    | pid6       | pid5    | pid4    | pid3    | pid2    | pid1    | pid0    |
| FLT8 TBL_ID       | 0x031F- $\overline{W}$ | msk7    | msk6       | msk5    | msk4    | msk3    | msk2    | msk1    | msk0    |
|                   |                        | tblid_7 | tblid_6    | tblid_5 | tblid_4 | tblid_3 | tblid_2 | tblid_1 | tblid_0 |
| FLT8 ADR BYTE0    | 0x0360- $\overline{W}$ | msk7    | msk6       | msk5    | msk4    | msk3    | msk2    | msk1    | msk0    |
|                   |                        | adr7    | adr6       | adr5    | adr4    | adr3    | adr2    | adr1    | adr0    |
| FLT8 ADR BYTE1    | 0x0361- $\overline{W}$ | msk7    | msk6       | msk5    | msk4    | msk3    | msk2    | msk1    | msk0    |
|                   |                        | adr7    | adr6       | adr5    | adr4    | adr3    | adr2    | adr1    | adr0    |
| FLT8 ADR BYTE2    | 0x0362- $\overline{W}$ | msk7    | msk6       | msk5    | msk4    | msk3    | msk2    | msk1    | msk0    |
|                   |                        | adr7    | adr6       | adr5    | adr4    | adr3    | adr2    | adr1    | adr0    |
| FLT8 ADR BYTE3    | 0x0363- $\overline{W}$ | msk7    | msk6       | msk5    | msk4    | msk3    | msk2    | msk1    | msk0    |
|                   |                        | adr7    | adr6       | adr5    | adr4    | adr3    | adr2    | adr1    | adr0    |
| FLT8 ADR BYTE4    | 0x0364- $\overline{W}$ | msk7    | msk6       | msk5    | msk4    | msk3    | msk2    | msk1    | msk0    |
|                   |                        | adr7    | adr6       | adr5    | adr4    | adr3    | adr2    | adr1    | adr0    |
| FLT8 ADR BYTE5    | 0x0365- $\overline{W}$ | msk7    | msk6       | msk5    | msk4    | msk3    | msk2    | msk1    | msk0    |
|                   |                        | adr7    | adr6       | adr5    | adr4    | adr3    | adr2    | adr1    | adr0    |
| FLT8 ADR BYTE6    | 0x0366- $\overline{W}$ | msk7    | msk6       | msk5    | msk4    | msk3    | msk2    | msk1    | msk0    |
|                   |                        | adr7    | adr6       | adr5    | adr4    | adr3    | adr2    | adr1    | adr0    |
| FLT9 CNTRL        | 0x0367- $\overline{W}$ | –       | equal_cond | enable  | pid12   | pid11   | pid10   | pid9    | pid8    |
|                   |                        | pid7    | pid6       | pid5    | pid4    | pid3    | pid2    | pid1    | pid0    |

## DVB compliant descrambler

SAA7206H

| REGISTER<br>FUNCTION | ADDRESS<br>(HEX)  | BITS    |            |         |         |         |         |         |         |
|----------------------|-------------------|---------|------------|---------|---------|---------|---------|---------|---------|
|                      |                   | 15/7    | 14/6       | 13/5    | 12/4    | 11/3    | 10/2    | 9/1     | 8/0     |
| FLT9 TBL_ID          | 0x0368- $\bar{W}$ | msk7    | msk6       | msk5    | msk4    | msk3    | msk2    | msk1    | msk0    |
|                      |                   | tblid_7 | tblid_6    | tblid_5 | tblid_4 | tblid_3 | tblid_2 | tblid_1 | tblid_0 |
| FLT9 ADR BYTE0       | 0x0369- $\bar{W}$ | msk7    | msk6       | msk5    | msk4    | msk3    | msk2    | msk1    | msk0    |
|                      |                   | adr7    | adr6       | adr5    | adr4    | adr3    | adr2    | adr1    | adr0    |
| FLT9 ADR BYTE1       | 0x036A- $\bar{W}$ | msk7    | msk6       | msk5    | msk4    | msk3    | msk2    | msk1    | msk0    |
|                      |                   | adr7    | adr6       | adr5    | adr4    | adr3    | adr2    | adr1    | adr0    |
| FLT9 ADR BYTE2       | 0x036B- $\bar{W}$ | msk7    | msk6       | msk5    | msk4    | msk3    | msk2    | msk1    | msk0    |
|                      |                   | adr7    | adr6       | adr5    | adr4    | adr3    | adr2    | adr1    | adr0    |
| FLT9 ADR BYTE3       | 0x036C- $\bar{W}$ | msk7    | msk6       | msk5    | msk4    | msk3    | msk2    | msk1    | msk0    |
|                      |                   | adr7    | adr6       | adr5    | adr4    | adr3    | adr2    | adr1    | adr0    |
| FLT9 ADR BYTE4       | 0x036D- $\bar{W}$ | msk7    | msk6       | msk5    | msk4    | msk3    | msk2    | msk1    | msk0    |
|                      |                   | adr7    | adr6       | adr5    | adr4    | adr3    | adr2    | adr1    | adr0    |
| FLT9 ADR BYTE5       | 0x036E- $\bar{W}$ | msk7    | msk6       | msk5    | msk4    | msk3    | msk2    | msk1    | msk0    |
|                      |                   | adr7    | adr6       | adr5    | adr4    | adr3    | adr2    | adr1    | adr0    |
| FLT9 ADR BYTE6       | 0x036F- $\bar{W}$ | msk7    | msk6       | msk5    | msk4    | msk3    | msk2    | msk1    | msk0    |
|                      |                   | adr7    | adr6       | adr5    | adr4    | adr3    | adr2    | adr1    | adr0    |
| FLT10 CNTRL          | 0x0370- $\bar{W}$ | –       | equal_cond | enable  | pid12   | pid11   | pid10   | pid9    | pid8    |
|                      |                   | pid7    | pid6       | pid5    | pid4    | pid3    | pid2    | pid1    | pid0    |
| FLT10 TBL_ID         | 0x0371- $\bar{W}$ | msk7    | msk6       | msk5    | msk4    | msk3    | msk2    | msk1    | msk0    |
|                      |                   | tblid_7 | tblid_6    | tblid_5 | tblid_4 | tblid_3 | tblid_2 | tblid_1 | tblid_0 |
| FLT10 ADR<br>BYTE0   | 0x0372- $\bar{W}$ | msk7    | msk6       | msk5    | msk4    | msk3    | msk2    | msk1    | msk0    |
|                      |                   | adr7    | adr6       | adr5    | adr4    | adr3    | adr2    | adr1    | adr0    |
| FLT10 ADR<br>BYTE1   | 0x0373- $\bar{W}$ | msk7    | msk6       | msk5    | msk4    | msk3    | msk2    | msk1    | msk0    |
|                      |                   | adr7    | adr6       | adr5    | adr4    | adr3    | adr2    | adr1    | adr0    |
| FLT10 ADR<br>BYTE2   | 0x0374- $\bar{W}$ | msk7    | msk6       | msk5    | msk4    | msk3    | msk2    | msk1    | msk0    |
|                      |                   | adr7    | adr6       | adr5    | adr4    | adr3    | adr2    | adr1    | adr0    |
| FLT10 ADR<br>BYTE3   | 0x0375- $\bar{W}$ | msk7    | msk6       | msk5    | msk4    | msk3    | msk2    | msk1    | msk0    |
|                      |                   | adr7    | adr6       | adr5    | adr4    | adr3    | adr2    | adr1    | adr0    |
| FLT10 ADR<br>BYTE4   | 0x0376- $\bar{W}$ | msk7    | msk6       | msk5    | msk4    | msk3    | msk2    | msk1    | msk0    |
|                      |                   | adr7    | adr6       | adr5    | adr4    | adr3    | adr2    | adr1    | adr0    |

## DVB compliant descrambler

SAA7206H

| REGISTER<br>FUNCTION | ADDRESS<br>(HEX)  | BITS    |            |         |         |         |         |         |         |
|----------------------|-------------------|---------|------------|---------|---------|---------|---------|---------|---------|
|                      |                   | 15/7    | 14/6       | 13/5    | 12/4    | 11/3    | 10/2    | 9/1     | 8/0     |
| FLT10 ADR<br>BYTE5   | 0x0377- $\bar{W}$ | msk7    | msk6       | msk5    | msk4    | msk3    | msk2    | msk1    | msk0    |
|                      |                   | adr7    | adr6       | adr5    | adr4    | adr3    | adr2    | adr1    | adr0    |
| FLT10 ADR<br>BYTE6   | 0x0378- $\bar{W}$ | msk7    | msk6       | msk5    | msk4    | msk3    | msk2    | msk1    | msk0    |
|                      |                   | adr7    | adr6       | adr5    | adr4    | adr3    | adr2    | adr1    | adr0    |
| FLT11 CNTRL          | 0x0379- $\bar{W}$ | –       | equal_cond | enable  | pid12   | pid11   | pid10   | pid9    | pid8    |
|                      |                   | pid7    | pid6       | pid5    | pid4    | pid3    | pid2    | pid1    | pid0    |
| FLT11 TBL_ID         | 0x037A- $\bar{W}$ | msk7    | msk6       | msk5    | msk4    | msk3    | msk2    | msk1    | msk0    |
|                      |                   | tblid_7 | tblid_6    | tblid_5 | tblid_4 | tblid_3 | tblid_2 | tblid_1 | tblid_0 |
| FLT11 ADR<br>BYTE0   | 0x037B- $\bar{W}$ | msk7    | msk6       | msk5    | msk4    | msk3    | msk2    | msk1    | msk0    |
|                      |                   | adr7    | adr6       | adr5    | adr4    | adr3    | adr2    | adr1    | adr0    |
| FLT11 ADR<br>BYTE1   | 0x037C- $\bar{W}$ | msk7    | msk6       | msk5    | msk4    | msk3    | msk2    | msk1    | msk0    |
|                      |                   | adr7    | adr6       | adr5    | adr4    | adr3    | adr2    | adr1    | adr0    |
| FLT11 ADR<br>BYTE2   | 0x037D- $\bar{W}$ | msk7    | msk6       | msk5    | msk4    | msk3    | msk2    | msk1    | msk0    |
|                      |                   | adr7    | adr6       | adr5    | adr4    | adr3    | adr2    | adr1    | adr0    |
| FLT11 ADR<br>BYTE3   | 0x037E- $\bar{W}$ | msk7    | msk6       | msk5    | msk4    | msk3    | msk2    | msk1    | msk0    |
|                      |                   | adr7    | adr6       | adr5    | adr4    | adr3    | adr2    | adr1    | adr0    |
| FLT11 ADR<br>BYTE4   | 0x037F- $\bar{W}$ | msk7    | msk6       | msk5    | msk4    | msk3    | msk2    | msk1    | msk0    |
|                      |                   | adr7    | adr6       | adr5    | adr4    | adr3    | adr2    | adr1    | adr0    |
| FLT11 ADR<br>BYTE5   | 0x0380- $\bar{W}$ | msk7    | msk6       | msk5    | msk4    | msk3    | msk2    | msk1    | msk0    |
|                      |                   | adr7    | adr6       | adr5    | adr4    | adr3    | adr2    | adr1    | adr0    |
| FLT11 ADR<br>BYTE6   | 0x0381- $\bar{W}$ | msk7    | msk6       | msk5    | msk4    | msk3    | msk2    | msk1    | msk0    |
|                      |                   | adr7    | adr6       | adr5    | adr4    | adr3    | adr2    | adr1    | adr0    |
| FLT12 CNTRL          | 0x0382- $\bar{W}$ | –       | equal_cond | enable  | pid12   | pid11   | pid10   | pid9    | pid8    |
|                      |                   | pid7    | pid6       | pid5    | pid4    | pid3    | pid2    | pid1    | pid0    |
| FLT12 TBL_ID         | 0x0383- $\bar{W}$ | msk7    | msk6       | msk5    | msk4    | msk3    | msk2    | msk1    | msk0    |
|                      |                   | tblid_7 | tblid_6    | tblid_5 | tblid_4 | tblid_3 | tblid_2 | tblid_1 | tblid_0 |
| FLT12 ADR<br>BYTE0   | 0x0384- $\bar{W}$ | msk7    | msk6       | msk5    | msk4    | msk3    | msk2    | msk1    | msk0    |
|                      |                   | adr7    | adr6       | adr5    | adr4    | adr3    | adr2    | adr1    | adr0    |
| FLT12 ADR<br>BYTE1   | 0x0385- $\bar{W}$ | msk7    | msk6       | msk5    | msk4    | msk3    | msk2    | msk1    | msk0    |
|                      |                   | adr7    | adr6       | adr5    | adr4    | adr3    | adr2    | adr1    | adr0    |

## DVB compliant descrambler

SAA7206H

| REGISTER<br>FUNCTION | ADDRESS<br>(HEX)       | BITS    |            |         |         |         |         |         |         |
|----------------------|------------------------|---------|------------|---------|---------|---------|---------|---------|---------|
|                      |                        | 15/7    | 14/6       | 13/5    | 12/4    | 11/3    | 10/2    | 9/1     | 8/0     |
| FLT12 ADR<br>BYTE2   | 0x0386- $\overline{W}$ | msk7    | msk6       | msk5    | msk4    | msk3    | msk2    | msk1    | msk0    |
|                      |                        | adr7    | adr6       | adr5    | adr4    | adr3    | adr2    | adr1    | adr0    |
| FLT12 ADR<br>BYTE3   | 0x0387- $\overline{W}$ | msk7    | msk6       | msk5    | msk4    | msk3    | msk2    | msk1    | msk0    |
|                      |                        | adr7    | adr6       | adr5    | adr4    | adr3    | adr2    | adr1    | adr0    |
| FLT12 ADR<br>BYTE4   | 0x0388- $\overline{W}$ | msk7    | msk6       | msk5    | msk4    | msk3    | msk2    | msk1    | msk0    |
|                      |                        | adr7    | adr6       | adr5    | adr4    | adr3    | adr2    | adr1    | adr0    |
| FLT12 ADR<br>BYTE5   | 0x0389- $\overline{W}$ | msk7    | msk6       | msk5    | msk4    | msk3    | msk2    | msk1    | msk0    |
|                      |                        | adr7    | adr6       | adr5    | adr4    | adr3    | adr2    | adr1    | adr0    |
| FLT12 ADR<br>BYTE6   | 0x038A- $\overline{W}$ | msk7    | msk6       | msk5    | msk4    | msk3    | msk2    | msk1    | msk0    |
|                      |                        | adr7    | adr6       | adr5    | adr4    | adr3    | adr2    | adr1    | adr0    |
| FLT13 CNTRL          | 0x038B- $\overline{W}$ | –       | equal_cond | enable  | pid12   | pid11   | pid10   | pid9    | pid8    |
|                      |                        | pid7    | pid6       | pid5    | pid4    | pid3    | pid2    | pid1    | pid0    |
| FLT13 TBL_ID         | 0x038C- $\overline{W}$ | msk7    | msk6       | msk5    | msk4    | msk3    | msk2    | msk1    | msk0    |
|                      |                        | tblid_7 | tblid_6    | tblid_5 | tblid_4 | tblid_3 | tblid_2 | tblid_1 | tblid_0 |
| FLT13 ADR<br>BYTE0   | 0x038D- $\overline{W}$ | msk7    | msk6       | msk5    | msk4    | msk3    | msk2    | msk1    | msk0    |
|                      |                        | adr7    | adr6       | adr5    | adr4    | adr3    | adr2    | adr1    | adr0    |
| FLT13 ADR<br>BYTE1   | 0x038E- $\overline{W}$ | msk7    | msk6       | msk5    | msk4    | msk3    | msk2    | msk1    | msk0    |
|                      |                        | adr7    | adr6       | adr5    | adr4    | adr3    | adr2    | adr1    | adr0    |
| FLT13 ADR<br>BYTE2   | 0x038F- $\overline{W}$ | msk7    | msk6       | msk5    | msk4    | msk3    | msk2    | msk1    | msk0    |
|                      |                        | adr7    | adr6       | adr5    | adr4    | adr3    | adr2    | adr1    | adr0    |
| FLT13 ADR<br>BYTE3   | 0x0390- $\overline{W}$ | msk7    | msk6       | msk5    | msk4    | msk3    | msk2    | msk1    | msk0    |
|                      |                        | adr7    | adr6       | adr5    | adr4    | adr3    | adr2    | adr1    | adr0    |
| FLT13 ADR<br>BYTE4   | 0x0391- $\overline{W}$ | msk7    | msk6       | msk5    | msk4    | msk3    | msk2    | msk1    | msk0    |
|                      |                        | adr7    | adr6       | adr5    | adr4    | adr3    | adr2    | adr1    | adr0    |
| FLT13 ADR<br>BYTE5   | 0x0392- $\overline{W}$ | msk7    | msk6       | msk5    | msk4    | msk3    | msk2    | msk1    | msk0    |
|                      |                        | adr7    | adr6       | adr5    | adr4    | adr3    | adr2    | adr1    | adr0    |
| FLT13 ADR<br>BYTE6   | 0x0393- $\overline{W}$ | msk7    | msk6       | msk5    | msk4    | msk3    | msk2    | msk1    | msk0    |
|                      |                        | adr7    | adr6       | adr5    | adr4    | adr3    | adr2    | adr1    | adr0    |
| FLT14 CNTRL          | 0x0394- $\overline{W}$ | –       | equal_cond | enable  | pid12   | pid11   | pid10   | pid9    | pid8    |
|                      |                        | pid7    | pid6       | pid5    | pid4    | pid3    | pid2    | pid1    | pid0    |

## DVB compliant descrambler

SAA7206H

| REGISTER<br>FUNCTION | ADDRESS<br>(HEX)       | BITS    |            |         |         |         |         |         |         |
|----------------------|------------------------|---------|------------|---------|---------|---------|---------|---------|---------|
|                      |                        | 15/7    | 14/6       | 13/5    | 12/4    | 11/3    | 10/2    | 9/1     | 8/0     |
| FLT14 TBL_ID         | 0x0395- $\overline{W}$ | msk7    | msk6       | msk5    | msk4    | msk3    | msk2    | msk1    | msk0    |
|                      |                        | tblid_7 | tblid_6    | tblid_5 | tblid_4 | tblid_3 | tblid_2 | tblid_1 | tblid_0 |
| FLT14 ADR<br>BYTE0   | 0x0396- $\overline{W}$ | msk7    | msk6       | msk5    | msk4    | msk3    | msk2    | msk1    | msk0    |
|                      |                        | adr7    | adr6       | adr5    | adr4    | adr3    | adr2    | adr1    | adr0    |
| FLT14 ADR<br>BYTE1   | 0x0397- $\overline{W}$ | msk7    | msk6       | msk5    | msk4    | msk3    | msk2    | msk1    | msk0    |
|                      |                        | adr7    | adr6       | adr5    | adr4    | adr3    | adr2    | adr1    | adr0    |
| FLT14 ADR<br>BYTE2   | 0x0398- $\overline{W}$ | msk7    | msk6       | msk5    | msk4    | msk3    | msk2    | msk1    | msk0    |
|                      |                        | adr7    | adr6       | adr5    | adr4    | adr3    | adr2    | adr1    | adr0    |
| FLT14 ADR<br>BYTE3   | 0x0399- $\overline{W}$ | msk7    | msk6       | msk5    | msk4    | msk3    | msk2    | msk1    | msk0    |
|                      |                        | adr7    | adr6       | adr5    | adr4    | adr3    | adr2    | adr1    | adr0    |
| FLT14 ADR<br>BYTE4   | 0x039A- $\overline{W}$ | msk7    | msk6       | msk5    | msk4    | msk3    | msk2    | msk1    | msk0    |
|                      |                        | adr7    | adr6       | adr5    | adr4    | adr3    | adr2    | adr1    | adr0    |
| FLT14 ADR<br>BYTE5   | 0x039B- $\overline{W}$ | msk7    | msk6       | msk5    | msk4    | msk3    | msk2    | msk1    | msk0    |
|                      |                        | adr7    | adr6       | adr5    | adr4    | adr3    | adr2    | adr1    | adr0    |
| FLT14 ADR<br>BYTE6   | 0x039C- $\overline{W}$ | msk7    | msk6       | msk5    | msk4    | msk3    | msk2    | msk1    | msk0    |
|                      |                        | adr7    | adr6       | adr5    | adr4    | adr3    | adr2    | adr1    | adr0    |
| FLT15 CNTRL          | 0x039D- $\overline{W}$ | –       | equal_cond | enable  | pid12   | pid11   | pid10   | pid9    | pid8    |
|                      |                        | pid7    | pid6       | pid5    | pid4    | pid3    | pid2    | pid1    | pid0    |
| FLT15 TBL_ID         | 0x039E- $\overline{W}$ | msk7    | msk6       | msk5    | msk4    | msk3    | msk2    | msk1    | msk0    |
|                      |                        | tblid_7 | tblid_6    | tblid_5 | tblid_4 | tblid_3 | tblid_2 | tblid_1 | tblid_0 |
| FLT15 ADR<br>BYTE0   | 0x039F- $\overline{W}$ | msk7    | msk6       | msk5    | msk4    | msk3    | msk2    | msk1    | msk0    |
|                      |                        | adr7    | adr6       | adr5    | adr4    | adr3    | adr2    | adr1    | adr0    |
| FLT15 ADR<br>BYTE1   | 0x03A0- $\overline{W}$ | msk7    | msk6       | msk5    | msk4    | msk3    | msk2    | msk1    | msk0    |
|                      |                        | adr7    | adr6       | adr5    | adr4    | adr3    | adr2    | adr1    | adr0    |
| FLT15 ADR<br>BYTE2   | 0x03A1- $\overline{W}$ | msk7    | msk6       | msk5    | msk4    | msk3    | msk2    | msk1    | msk0    |
|                      |                        | adr7    | adr6       | adr5    | adr4    | adr3    | adr2    | adr1    | adr0    |
| FLT15 ADR<br>BYTE3   | 0x03A2- $\overline{W}$ | msk7    | msk6       | msk5    | msk4    | msk3    | msk2    | msk1    | msk0    |
|                      |                        | adr7    | adr6       | adr5    | adr4    | adr3    | adr2    | adr1    | adr0    |
| FLT15 ADR<br>BYTE4   | 0x03A3- $\overline{W}$ | msk7    | msk6       | msk5    | msk4    | msk3    | msk2    | msk1    | msk0    |
|                      |                        | adr7    | adr6       | adr5    | adr4    | adr3    | adr2    | adr1    | adr0    |



## DVB compliant descrambler

SAA7206H

| REGISTER<br>FUNCTION | ADDRESS<br>(HEX)  | BITS    |            |         |         |         |         |         |         |
|----------------------|-------------------|---------|------------|---------|---------|---------|---------|---------|---------|
|                      |                   | 15/7    | 14/6       | 13/5    | 12/4    | 11/3    | 10/2    | 9/1     | 8/0     |
| FLT15 ADR<br>BYTE5   | 0x03A4- $\bar{W}$ | msk7    | msk6       | msk5    | msk4    | msk3    | msk2    | msk1    | msk0    |
|                      |                   | adr7    | adr6       | adr5    | adr4    | adr3    | adr2    | adr1    | adr0    |
| FLT15 ADR<br>BYTE6   | 0x03A5- $\bar{W}$ | msk7    | msk6       | msk5    | msk4    | msk3    | msk2    | msk1    | msk0    |
|                      |                   | adr7    | adr6       | adr5    | adr4    | adr3    | adr2    | adr1    | adr0    |
| FLT16 PID MASK       | 0x03A6- $\bar{W}$ | –       | –          | –       | msk12   | msk11   | msk10   | msk9    | msk8    |
|                      |                   | msk7    | msk6       | msk5    | msk4    | msk3    | msk2    | msk1    | msk0    |
| FLT16 CNTRL          | 0x03A7- $\bar{W}$ | –       | equal_cond | enable  | pid12   | pid11   | pid10   | pid9    | pid8    |
|                      |                   | pid7    | pid6       | pid5    | pid4    | pid3    | pid2    | pid1    | pid0    |
| FLT16 TBL_ID         | 0x03A8- $\bar{W}$ | msk7    | msk6       | msk5    | msk4    | msk3    | msk2    | msk1    | msk0    |
|                      |                   | tblid_7 | tblid_6    | tblid_5 | tblid_4 | tblid_3 | tblid_2 | tblid_1 | tblid_0 |
| FLT16 ADR<br>BYTE0   | 0x03A9- $\bar{W}$ | msk7    | msk6       | msk5    | msk4    | msk3    | msk2    | msk1    | msk0    |
|                      |                   | adr7    | adr6       | adr5    | adr4    | adr3    | adr2    | adr1    | adr0    |
| FLT16 ADR<br>BYTE1   | 0x03AA- $\bar{W}$ | msk7    | msk6       | msk5    | msk4    | msk3    | msk2    | msk1    | msk0    |
|                      |                   | adr7    | adr6       | adr5    | adr4    | adr3    | adr2    | adr1    | adr0    |
| FLT16 ADR<br>BYTE2   | 0x03AB- $\bar{W}$ | msk7    | msk6       | msk5    | msk4    | msk3    | msk2    | msk1    | msk0    |
|                      |                   | adr7    | adr6       | adr5    | adr4    | adr3    | adr2    | adr1    | adr0    |
| FLT16 ADR<br>BYTE3   | 0x03AC- $\bar{W}$ | msk7    | msk6       | msk5    | msk4    | msk3    | msk2    | msk1    | msk0    |
|                      |                   | adr7    | adr6       | adr5    | adr4    | adr3    | adr2    | adr1    | adr0    |
| FLT16 ADR<br>BYTE4   | 0x03AD- $\bar{W}$ | msk7    | msk6       | msk5    | msk4    | msk3    | msk2    | msk1    | msk0    |
|                      |                   | adr7    | adr6       | adr5    | adr4    | adr3    | adr2    | adr1    | adr0    |
| FLT16 ADR<br>BYTE5   | 0x03AE- $\bar{W}$ | msk7    | msk6       | msk5    | msk4    | msk3    | msk2    | msk1    | msk0    |
|                      |                   | adr7    | adr6       | adr5    | adr4    | adr3    | adr2    | adr1    | adr0    |
| FLT16 ADR<br>BYTE6   | 0x03AF- $\bar{W}$ | msk7    | msk6       | msk5    | msk4    | msk3    | msk2    | msk1    | msk0    |
|                      |                   | adr7    | adr6       | adr5    | adr4    | adr3    | adr2    | adr1    | adr0    |
| FLT16 ADR<br>BYTE7   | 0x03B0- $\bar{W}$ | msk7    | msk6       | msk5    | msk4    | msk3    | msk2    | msk1    | msk0    |
|                      |                   | adr7    | adr6       | adr5    | adr4    | adr3    | adr2    | adr1    | adr0    |
| FLT16 ADR<br>BYTE8   | 0x03B1- $\bar{W}$ | msk7    | msk6       | msk5    | msk4    | msk3    | msk2    | msk1    | msk0    |
|                      |                   | adr7    | adr6       | adr5    | adr4    | adr3    | adr2    | adr1    | adr0    |
| FLT16 ADR<br>BYTE9   | 0x03B2- $\bar{W}$ | msk7    | msk6       | msk5    | msk4    | msk3    | msk2    | msk1    | msk0    |
|                      |                   | adr7    | adr6       | adr5    | adr4    | adr3    | adr2    | adr1    | adr0    |

## DVB compliant descrambler

SAA7206H

| REGISTER<br>FUNCTION | ADDRESS<br>(HEX)  | BITS    |            |         |         |         |         |         |         |
|----------------------|-------------------|---------|------------|---------|---------|---------|---------|---------|---------|
|                      |                   | 15/7    | 14/6       | 13/5    | 12/4    | 11/3    | 10/2    | 9/1     | 8/0     |
| FLT16 ADR<br>BYTE10  | 0x03B3- $\bar{W}$ | msk7    | msk6       | msk5    | msk4    | msk3    | msk2    | msk1    | msk0    |
|                      |                   | adr7    | adr6       | adr5    | adr4    | adr3    | adr2    | adr1    | adr0    |
| FLT16 ADR<br>BYTE11  | 0x03B4- $\bar{W}$ | msk7    | msk6       | msk5    | msk4    | msk3    | msk2    | msk1    | msk0    |
|                      |                   | adr7    | adr6       | adr5    | adr4    | adr3    | adr2    | adr1    | adr0    |
| FLT16 ADR<br>BYTE12  | 0x03B5- $\bar{W}$ | msk7    | msk6       | msk5    | msk4    | msk3    | msk2    | msk1    | msk0    |
|                      |                   | adr7    | adr6       | adr5    | adr4    | adr3    | adr2    | adr1    | adr0    |
| FLT16 ADR<br>BYTE13  | 0x03B6- $\bar{W}$ | msk7    | msk6       | msk5    | msk4    | msk3    | msk2    | msk1    | msk0    |
|                      |                   | adr7    | adr6       | adr5    | adr4    | adr3    | adr2    | adr1    | adr0    |
| FLT16 ADR<br>BYTE14  | 0x03B7- $\bar{W}$ | msk7    | msk6       | msk5    | msk4    | msk3    | msk2    | msk1    | msk0    |
|                      |                   | adr7    | adr6       | adr5    | adr4    | adr3    | adr2    | adr1    | adr0    |
| FLT16 ADR<br>BYTE15  | 0x03B8- $\bar{W}$ | msk7    | msk6       | msk5    | msk4    | msk3    | msk2    | msk1    | msk0    |
|                      |                   | adr7    | adr6       | adr5    | adr4    | adr3    | adr2    | adr1    | adr0    |
| FLT16 ADR<br>BYTE16  | 0x03B9- $\bar{W}$ | msk7    | msk6       | msk5    | msk4    | msk3    | msk2    | msk1    | msk0    |
|                      |                   | adr7    | adr6       | adr5    | adr4    | adr3    | adr2    | adr1    | adr0    |
| FLT17 PID MASK       | 0x03BA- $\bar{W}$ | –       | –          | –       | msk12   | msk11   | msk10   | msk9    | msk8    |
|                      |                   | msk7    | msk6       | msk5    | msk4    | msk3    | msk2    | msk1    | msk0    |
| FLT17 CNTRL          | 0x03BB- $\bar{W}$ | –       | equal_cond | enable  | pid12   | pid11   | pid10   | pid9    | pid8    |
|                      |                   | pid7    | pid6       | pid5    | pid4    | pid3    | pid2    | pid1    | pid0    |
| FLT17 TBL_ID         | 0x03BC- $\bar{W}$ | msk7    | msk6       | msk5    | msk4    | msk3    | msk2    | msk1    | msk0    |
|                      |                   | tblid_7 | tblid_6    | tblid_5 | tblid_4 | tblid_3 | tblid_2 | tblid_1 | tblid_0 |
| FLT17 ADR<br>BYTE0   | 0x03BD- $\bar{W}$ | msk7    | msk6       | msk5    | msk4    | msk3    | msk2    | msk1    | msk0    |
|                      |                   | adr7    | adr6       | adr5    | adr4    | adr3    | adr2    | adr1    | adr0    |
| FLT17 ADR<br>BYTE1   | 0x03BE- $\bar{W}$ | msk7    | msk6       | msk5    | msk4    | msk3    | msk2    | msk1    | msk0    |
|                      |                   | adr7    | adr6       | adr5    | adr4    | adr3    | adr2    | adr1    | adr0    |
| FLT17 ADR<br>BYTE2   | 0x03BF- $\bar{W}$ | msk7    | msk6       | msk5    | msk4    | msk3    | msk2    | msk1    | msk0    |
|                      |                   | adr7    | adr6       | adr5    | adr4    | adr3    | adr2    | adr1    | adr0    |
| FLT17 ADR<br>BYTE3   | 0x03C0- $\bar{W}$ | msk7    | msk6       | msk5    | msk4    | msk3    | msk2    | msk1    | msk0    |
|                      |                   | adr7    | adr6       | adr5    | adr4    | adr3    | adr2    | adr1    | adr0    |
| FLT17 ADR<br>BYTE4   | 0x03C1- $\bar{W}$ | msk7    | msk6       | msk5    | msk4    | msk3    | msk2    | msk1    | msk0    |
|                      |                   | adr7    | adr6       | adr5    | adr4    | adr3    | adr2    | adr1    | adr0    |

## DVB compliant descrambler

## SAA7206H

| REGISTER<br>FUNCTION | ADDRESS<br>(HEX)    | BITS |      |      |      |      |      |      |      |
|----------------------|---------------------|------|------|------|------|------|------|------|------|
|                      |                     | 15/7 | 14/6 | 13/5 | 12/4 | 11/3 | 10/2 | 9/1  | 8/0  |
| FLT17 ADR<br>BYTE5   | 0x03C2- $\bar{W}$   | msk7 | msk6 | msk5 | msk4 | msk3 | msk2 | msk1 | msk0 |
|                      |                     | adr7 | adr6 | adr5 | adr4 | adr3 | adr2 | adr1 | adr0 |
| FLT17 ADR<br>BYTE6   | 0x03C3- $\bar{W}$   | msk7 | msk6 | msk5 | msk4 | msk3 | msk2 | msk1 | msk0 |
|                      |                     | adr7 | adr6 | adr5 | adr4 | adr3 | adr2 | adr1 | adr0 |
| FLT17 ADR<br>BYTE7   | 0x03C4- $\bar{W}$   | msk7 | msk6 | msk5 | msk4 | msk3 | msk2 | msk1 | msk0 |
|                      |                     | adr7 | adr6 | adr5 | adr4 | adr3 | adr2 | adr1 | adr0 |
| FLT17 ADR<br>BYTE8   | 0x03C5- $\bar{W}$   | msk7 | msk6 | msk5 | msk4 | msk3 | msk2 | msk1 | msk0 |
|                      |                     | adr7 | adr6 | adr5 | adr4 | adr3 | adr2 | adr1 | adr0 |
| FLT17 ADR<br>BYTE9   | 0x03C6- $\bar{W}$   | msk7 | msk6 | msk5 | msk4 | msk3 | msk2 | msk1 | msk0 |
|                      |                     | adr7 | adr6 | adr5 | adr4 | adr3 | adr2 | adr1 | adr0 |
| FLT17 ADR<br>BYTE10  | 0x03C7- $\bar{W}$   | msk7 | msk6 | msk5 | msk4 | msk3 | msk2 | msk1 | msk0 |
|                      |                     | adr7 | adr6 | adr5 | adr4 | adr3 | adr2 | adr1 | adr0 |
| FLT17 ADR<br>BYTE11  | 0x03C8- $\bar{W}$   | msk7 | msk6 | msk5 | msk4 | msk3 | msk2 | msk1 | msk0 |
|                      |                     | adr7 | adr6 | adr5 | adr4 | adr3 | adr2 | adr1 | adr0 |
| FLT17 ADR<br>BYTE12  | 0x03C9- $\bar{W}$   | msk7 | msk6 | msk5 | msk4 | msk3 | msk2 | msk1 | msk0 |
|                      |                     | adr7 | adr6 | adr5 | adr4 | adr3 | adr2 | adr1 | adr0 |
| FLT17 ADR<br>BYTE13  | 0x03CA- $\bar{W}$   | msk7 | msk6 | msk5 | msk4 | msk3 | msk2 | msk1 | msk0 |
|                      |                     | adr7 | adr6 | adr5 | adr4 | adr3 | adr2 | adr1 | adr0 |
| FLT17 ADR<br>BYTE14  | 0x03CB- $\bar{W}$   | msk7 | msk6 | msk5 | msk4 | msk3 | msk2 | msk1 | msk0 |
|                      |                     | adr7 | adr6 | adr5 | adr4 | adr3 | adr2 | adr1 | adr0 |
| FLT17 ADR<br>BYTE15  | 0x03CC- $\bar{W}$   | msk7 | msk6 | msk5 | msk4 | msk3 | msk2 | msk1 | msk0 |
|                      |                     | adr7 | adr6 | adr5 | adr4 | adr3 | adr2 | adr1 | adr0 |
| FLT17 ADR<br>BYTE16  | 0x03CD- $\bar{W}$   | msk7 | msk6 | msk5 | msk4 | msk3 | msk2 | msk1 | msk0 |
|                      |                     | adr7 | adr6 | adr5 | adr4 | adr3 | adr2 | adr1 | adr0 |
| EMPTY                | 0x03CE to<br>0x0FFF | –    | –    | –    | –    | –    | –    | –    | –    |
|                      |                     | –    | –    | –    | –    | –    | –    | –    | –    |
| CTRL WRD0_<br>EVEN3  | 0x1000- $\bar{W}$   | cw63 | cw62 | cw61 | cw60 | cw59 | cw58 | cw57 | cw56 |
|                      |                     | cw55 | cw54 | cw53 | cw52 | cw51 | cw50 | cw49 | cw48 |
| CTRL_ WRD0_<br>EVEN2 | 0x1001- $\bar{W}$   | cw47 | cw46 | cw45 | cw44 | cw43 | cw42 | cw41 | cw40 |
|                      |                     | cw39 | cw38 | cw37 | cw36 | cw35 | cw34 | cw33 | cw32 |

## DVB compliant descrambler

SAA7206H

| REGISTER<br>FUNCTION | ADDRESS<br>(HEX)       | BITS |      |      |      |      |      |      |      |
|----------------------|------------------------|------|------|------|------|------|------|------|------|
|                      |                        | 15/7 | 14/6 | 13/5 | 12/4 | 11/3 | 10/2 | 9/1  | 8/0  |
| CTRL WRD0_<br>EVEN1  | 0x1002- $\overline{W}$ | cw31 | cw30 | cw29 | cw28 | cw27 | cw26 | cw25 | cw24 |
|                      |                        | cw23 | cw22 | cw21 | cw20 | cw19 | cw18 | cw17 | cw16 |
| CTRL_ WRD0_<br>EVEN0 | 0x1003- $\overline{W}$ | cw15 | cw14 | cw13 | cw12 | cw11 | cw10 | cw9  | cw8  |
|                      |                        | cw7  | cw6  | cw5  | cw4  | cw3  | cw2  | cw1  | cw0  |
| CTRL WRD0_<br>ODD3   | 0x1004- $\overline{W}$ | cw63 | cw62 | cw61 | cw60 | cw59 | cw58 | cw57 | cw56 |
|                      |                        | cw55 | cw54 | cw53 | cw52 | cw51 | cw50 | cw49 | cw48 |
| CTRL_ WRD0_<br>ODD2  | 0x1005- $\overline{W}$ | cw47 | cw46 | cw45 | cw44 | cw43 | cw42 | cw41 | cw40 |
|                      |                        | cw39 | cw38 | cw37 | cw36 | cw35 | cw34 | cw33 | cw32 |
| CTRL WRD0_<br>ODD1   | 0x1006- $\overline{W}$ | cw31 | cw30 | cw29 | cw28 | cw27 | cw26 | cw25 | cw24 |
|                      |                        | cw23 | cw22 | cw21 | cw20 | cw19 | cw18 | cw17 | cw16 |
| CTRL_ WRD0_<br>ODD0  | 0x1007- $\overline{W}$ | cw15 | cw14 | cw13 | cw12 | cw11 | cw10 | cw9  | cw8  |
|                      |                        | cw7  | cw6  | cw5  | cw4  | cw3  | cw2  | cw1  | cw0  |
| CTRL WRD1_<br>EVEN3  | 0x1008- $\overline{W}$ | cw63 | cw62 | cw61 | cw60 | cw59 | cw58 | cw57 | cw56 |
|                      |                        | cw55 | cw54 | cw53 | cw52 | cw51 | cw50 | cw49 | cw48 |
| CTRL_ WRD1_<br>EVEN2 | 0x1009- $\overline{W}$ | cw47 | cw46 | cw45 | cw44 | cw43 | cw42 | cw41 | cw40 |
|                      |                        | cw39 | cw38 | cw37 | cw36 | cw35 | cw34 | cw33 | cw32 |
| CTRL WRD1_<br>EVEN1  | 0x100A- $\overline{W}$ | cw31 | cw30 | cw29 | cw28 | cw27 | cw26 | cw25 | cw24 |
|                      |                        | cw23 | cw22 | cw21 | cw20 | cw19 | cw18 | cw17 | cw16 |
| CTRL_ WRD1_<br>EVEN0 | 0x100B- $\overline{W}$ | cw15 | cw14 | cw13 | cw12 | cw11 | cw10 | cw9  | cw8  |
|                      |                        | cw7  | cw6  | cw5  | cw4  | cw3  | cw2  | cw1  | cw0  |
| CTRL WRD1_<br>ODD3   | 0x100C- $\overline{W}$ | cw63 | cw62 | cw61 | cw60 | cw59 | cw58 | cw57 | cw56 |
|                      |                        | cw55 | cw54 | cw53 | cw52 | cw51 | cw50 | cw49 | cw48 |
| CTRL_ WRD1_<br>ODD2  | 0x100D- $\overline{W}$ | cw47 | cw46 | cw45 | cw44 | cw43 | cw42 | cw41 | cw40 |
|                      |                        | cw39 | cw38 | cw37 | cw36 | cw35 | cw34 | cw33 | cw32 |
| CTRL WRD1_<br>ODD1   | 0x100E- $\overline{W}$ | cw31 | cw30 | cw29 | cw28 | cw27 | cw26 | cw25 | cw24 |
|                      |                        | cw23 | cw22 | cw21 | cw20 | cw19 | cw18 | cw17 | cw16 |
| CTRL_ WRD1_<br>ODD0  | 0x100F- $\overline{W}$ | cw15 | cw14 | cw13 | cw12 | cw11 | cw10 | cw9  | cw8  |
|                      |                        | cw7  | cw6  | cw5  | cw4  | cw3  | cw2  | cw1  | cw0  |
| CTRL WRD2_<br>EVEN3  | 0x1010- $\overline{W}$ | cw63 | cw62 | cw61 | cw60 | cw59 | cw58 | cw57 | cw56 |
|                      |                        | cw55 | cw54 | cw53 | cw52 | cw51 | cw50 | cw49 | cw48 |

## DVB compliant descrambler

SAA7206H

| REGISTER<br>FUNCTION | ADDRESS<br>(HEX)       | BITS |      |      |      |      |       |      |      |
|----------------------|------------------------|------|------|------|------|------|-------|------|------|
|                      |                        | 15/7 | 14/6 | 13/5 | 12/4 | 11/3 | 10/2  | 9/1  | 8/0  |
| CTRL_WRD2_<br>EVEN2  | 0x1011- $\overline{W}$ | cw47 | cw46 | cw45 | cw44 | cw43 | cw42  | cw41 | cw40 |
|                      |                        | cw39 | cw38 | cw37 | cw36 | cw35 | cw34  | cw33 | cw32 |
| CTRL_WRD2_<br>EVEN1  | 0x1012- $\overline{W}$ | cw31 | cw30 | cw29 | cw28 | cw27 | cw26  | cw25 | cw24 |
|                      |                        | cw23 | cw22 | cw21 | cw20 | cw19 | cw18  | cw17 | cw16 |
| CTRL_WRD2_<br>EVEN0  | 0x1013- $\overline{W}$ | cw15 | cw14 | cw13 | cw12 | cw11 | cw10  | cw9  | cw8  |
|                      |                        | cw7  | cw6  | cw5  | cw4  | cw3  | cw2   | cw1  | cw0  |
| CTRL_WRD2_<br>ODD3   | 0x1014- $\overline{W}$ | cw63 | cw62 | cw61 | cw60 | cw59 | cw58  | cw57 | cw56 |
|                      |                        | cw55 | cw54 | cw53 | cw52 | cw51 | cw50  | cw49 | cw48 |
| CTRL_WRD2_<br>ODD2   | 0x1015- $\overline{W}$ | cw47 | cw46 | cw45 | cw44 | cw43 | cw42  | cw41 | cw40 |
|                      |                        | cw39 | cw38 | cw37 | cw36 | cw35 | cw34  | cw33 | cw32 |
| CTRL_WRD2_<br>ODD1   | 0x1016- $\overline{W}$ | cw31 | cw30 | cw29 | cw28 | cw27 | cw26  | cw25 | cw24 |
|                      |                        | cw23 | cw22 | cw21 | cw20 | cw19 | cw18  | cw17 | cw16 |
| CTRL_WRD2_<br>ODD0   | 0x1017- $\overline{W}$ | cw15 | cw14 | cw13 | cw12 | cw11 | cw10  | cw9  | cw8  |
|                      |                        | cw7  | cw6  | cw5  | cw4  | cw3  | cw2   | cw1  | cw0  |
| CTRL_WRD3_<br>EVEN3  | 0x1018- $\overline{W}$ | cw63 | cw62 | cw61 | cw60 | cw59 | cw58  | cw57 | cw56 |
|                      |                        | cw55 | cw54 | cw53 | cw52 | cw51 | cw50  | cw49 | cw48 |
| CTRL_WRD3_<br>EVEN2  | 0x1019- $\overline{W}$ | cw47 | cw46 | cw45 | cw44 | cw43 | cw42  | cw41 | cw40 |
|                      |                        | cw39 | cw38 | cw37 | cw36 | cw35 | cw34  | cw33 | cw32 |
| CTRL_WRD3_<br>EVEN1  | 0x101A- $\overline{W}$ | cw31 | cw30 | cw29 | cw28 | cw27 | cw26  | cw25 | cw24 |
|                      |                        | cw23 | cw22 | cw21 | cw20 | cw19 | cw18  | cw17 | cw16 |
| CTRL_WRD3_<br>EVEN0  | 0x101B- $\overline{W}$ | cw15 | cw14 | cw13 | cw12 | cw11 | cw10  | cw9  | cw8  |
|                      |                        | cw7  | cw6  | cw5  | cw4  | cw3  | cw2   | cw1  | cw0  |
| CTRL_WRD3_<br>ODD3   | 0x101C- $\overline{W}$ | cw63 | cw62 | cw61 | cw60 | cw59 | cw58  | cw57 | cw56 |
|                      |                        | cw55 | cw54 | cw53 | cw52 | cw51 | cw50  | cw49 | cw48 |
| CTRL_WRD3_<br>ODD2   | 0x101D- $\overline{W}$ | cw47 | cw46 | cw45 | cw44 | cw43 | cw42  | cw41 | cw40 |
|                      |                        | cw39 | cw38 | cw37 | cw36 | cw35 | cw34  | cw33 | cw32 |
| CTRL_WRD3_<br>ODD1   | 0x101E- $\overline{W}$ | cw31 | cw30 | cw29 | cw28 | cw27 | cw26  | cw25 | cw24 |
|                      |                        | cw23 | cw22 | cw21 | cw20 | cw19 | scw18 | cw17 | cw16 |
| CTRL_WRD3_<br>ODD0   | 0x101F- $\overline{W}$ | cw15 | cw14 | cw13 | cw12 | cw11 | cw10  | cw9  | cw8  |
|                      |                        | cw7  | cw6  | cw5  | cw4  | cw3  | cw2   | cw1  | cw0  |

## DVB compliant descrambler

SAA7206H

| REGISTER<br>FUNCTION | ADDRESS<br>(HEX)  | BITS |      |      |      |      |      |      |      |
|----------------------|-------------------|------|------|------|------|------|------|------|------|
|                      |                   | 15/7 | 14/6 | 13/5 | 12/4 | 11/3 | 10/2 | 9/1  | 8/0  |
| CTRL WRD4_<br>EVEN3  | 0x1020- W         | cw63 | cw62 | cw61 | cw60 | cw59 | cw58 | cw57 | cw56 |
|                      |                   | cw55 | cw54 | cw53 | cw52 | cw51 | cw50 | cw49 | cw48 |
| CTRL_ WRD4_<br>EVEN2 | 0x1021- W         | cw47 | cw46 | cw45 | cw44 | cw43 | cw42 | cw41 | cw40 |
|                      |                   | cw39 | cw38 | cw37 | cw36 | cw35 | cw34 | cw33 | cw32 |
| CTRL WRD4_<br>EVEN1  | 0x1022- W         | cw31 | cw30 | cw29 | cw28 | cw27 | cw26 | cw25 | cw24 |
|                      |                   | cw23 | cw22 | cw21 | cw20 | cw19 | cw18 | cw17 | cw16 |
| CTRL_ WRD4_<br>EVEN0 | 0x1023- W         | cw15 | cw14 | cw13 | cw12 | cw11 | cw10 | cw9  | cw8  |
|                      |                   | cw7  | cw6  | cw5  | cw4  | cw3  | cw2  | cw1  | cw0  |
| CTRL WRD4_<br>ODD3   | 0x1024- W         | cw63 | cw62 | cw61 | cw60 | cw59 | cw58 | cw57 | cw56 |
|                      |                   | cw55 | cw54 | cw53 | cw52 | cw51 | cw50 | cw49 | cw48 |
| CTRL_ WRD4_<br>ODD2  | 0x1025- W         | cw47 | cw46 | cw45 | cw44 | cw43 | cw42 | cw41 | cw40 |
|                      |                   | cw39 | cw38 | cw37 | cw36 | cw35 | cw34 | cw33 | cw32 |
| CTRL WRD4_<br>ODD1   | 0x1026- W         | cw31 | cw30 | cw29 | cw28 | cw27 | cw26 | cw25 | cw24 |
|                      |                   | cw23 | cw22 | cw21 | cw20 | cw19 | cw18 | cw17 | cw16 |
| CTRL_ WRD4_<br>ODD0  | 0x1027- W         | cw15 | cw14 | cw13 | cw12 | cw11 | cw10 | cw9  | cw8  |
|                      |                   | cw7  | cw6  | cw5  | cw4  | cw3  | cw2  | cw1  | cw0  |
| CTRL WRD5_<br>EVEN3  | 0x1028- W         | cw63 | cw62 | cw61 | cw60 | cw59 | cw58 | cw57 | cw56 |
|                      |                   | cw55 | cw54 | cw53 | cw52 | cw51 | cw50 | cw49 | cw48 |
| CTRL_ WRD5_<br>EVEN2 | 0x1029- W         | cw47 | cw46 | cw45 | cw44 | cw43 | cw42 | cw41 | cw40 |
|                      |                   | cw39 | cw38 | cw37 | cw36 | cw35 | cw34 | cw33 | cw32 |
| CTRL WRD5_<br>EVEN1  | 0x102A- W         | cw31 | cw30 | cw29 | cw28 | cw27 | cw26 | cw25 | cw24 |
|                      |                   | cw23 | cw22 | cw21 | cw20 | cw19 | cw18 | cw17 | cw16 |
| CTRL_ WRD5_<br>EVEN0 | 0x102B- W         | cw15 | cw14 | cw13 | cw12 | cw11 | cw10 | cw9  | cw8  |
|                      |                   | cw7  | cw6  | cw5  | cw4  | cw3  | cw2  | cw1  | cw0  |
| CTRL WRD5_<br>ODD3   | 0x102C- W         | cw63 | cw62 | cw61 | cw60 | cw59 | cw58 | cw57 | cw56 |
|                      |                   | cw55 | cw54 | cw53 | cw52 | cw51 | cw50 | cw49 | cw48 |
| CTRL_ WRD5_<br>ODD2  | 0x102D- $\bar{W}$ | cw47 | cw46 | cw45 | cw44 | cw43 | cw42 | cw41 | cw40 |
|                      |                   | cw39 | cw38 | cw37 | cw36 | cw35 | cw34 | cw33 | cw32 |
| CTRL WRD5_<br>ODD1   | 0x102E- $\bar{W}$ | cw31 | cw30 | cw29 | cw28 | cw27 | cw26 | cw25 | cw24 |
|                      |                   | cw23 | cw22 | cw21 | cw20 | cw19 | cw18 | cw17 | cw16 |

## DVB compliant descrambler

SAA7206H

| REGISTER<br>FUNCTION | ADDRESS<br>(HEX)       | BITS   |        |        |        |        |        |       |       |
|----------------------|------------------------|--------|--------|--------|--------|--------|--------|-------|-------|
|                      |                        | 15/7   | 14/6   | 13/5   | 12/4   | 11/3   | 10/2   | 9/1   | 8/0   |
| CTRL_WRD5_<br>ODD0   | 0x102F- $\bar{W}$      | cw15   | cw14   | cw13   | cw12   | cw11   | cw10   | cw9   | cw8   |
|                      |                        | cw7    | cw6    | cw5    | cw4    | cw3    | cw2    | cw1   | cw0   |
| DFLT_CTRL_<br>WRD3   | 0x1030- $\bar{W}$      | cw63   | cw62   | cw61   | cw60   | cw59   | cw58   | cw57  | cw56  |
|                      |                        | cw55   | cw54   | cw53   | cw52   | cw51   | cw50   | cw49  | cw48  |
| DFLT_CTRL_<br>WRD2   | 0x1031- $\bar{W}$      | cw47   | cw46   | cw45   | cw44   | cw43   | cw42   | cw41  | cw40  |
|                      |                        | cw39   | cw38   | cw37   | cw36   | cw35   | cw34   | cw33  | cw32  |
| DFLT_CTRL_<br>WRD1   | 0x1032- $\bar{W}$      | cw31   | cw30   | cw29   | cw28   | cw27   | cw26   | cw25  | cw24  |
|                      |                        | cw23   | cw22   | cw21   | cw20   | cw19   | cw18   | cw17  | cw16  |
| DFLT_CTRL_<br>WRD0   | 0x1033- $\bar{W}$      | cw15   | cw14   | cw13   | cw12   | cw11   | cw10   | cw9   | cw8   |
|                      |                        | cw7    | cw6    | cw5    | cw4    | cw3    | cw2    | cw1   | cw0   |
| EMPTY                | 0x1034 to<br>0x1FFF    | –      | –      | –      | –      | –      | –      | –     | –     |
|                      |                        | –      | –      | –      | –      | –      | –      | –     | –     |
| FLT0_BUFFER          | 0x2000 to<br>0x207F- R | data15 | data14 | data13 | data12 | data11 | data10 | data9 | data8 |
|                      |                        | data7  | data6  | data5  | data4  | data3  | data2  | data1 | data0 |
| EMPTY                | 0x2080 to<br>0x20FF    | –      | –      | –      | –      | –      | –      | –     | –     |
|                      |                        | –      | –      | –      | –      | –      | –      | –     | –     |
| FLT1_BUFFER          | 0x2100 to<br>0x217F- R | data15 | data14 | data13 | data12 | data11 | data10 | data9 | data8 |
|                      |                        | data7  | data6  | data5  | data4  | data3  | data2  | data1 | data0 |
| EMPTY                | 0x2180 to<br>0x21FF    | –      | –      | –      | –      | –      | –      | –     | –     |
|                      |                        | –      | –      | –      | –      | –      | –      | –     | –     |
| FLT2_BUFFER          | 0x2200 to<br>0x227F- R | data15 | data14 | data13 | data12 | data11 | data10 | data9 | data8 |
|                      |                        | data7  | data6  | data5  | data4  | data3  | data2  | data1 | data0 |
| EMPTY                | 0x2280 to<br>0x22FF    | –      | –      | –      | –      | –      | –      | –     | –     |
|                      |                        | –      | –      | –      | –      | –      | –      | –     | –     |
| FLT3_BUFFER          | 0x2300 to<br>0x237F- R | data15 | data14 | data13 | data12 | data11 | data10 | data9 | data8 |
|                      |                        | data7  | data6  | data5  | data4  | data3  | data2  | data1 | data0 |
| EMPTY                | 0x2380 to<br>0x23FF    | –      | –      | –      | –      | –      | –      | –     | –     |
|                      |                        | –      | –      | –      | –      | –      | –      | –     | –     |
| FLT4_BUFFER          | 0x2400 to<br>0x247F- R | data15 | data14 | data13 | data12 | data11 | data10 | data9 | data8 |
|                      |                        | data7  | data6  | data5  | data4  | data3  | data2  | data1 | data0 |

## DVB compliant descrambler

SAA7206H

| REGISTER<br>FUNCTION | ADDRESS<br>(HEX)       | BITS   |        |        |        |        |        |       |       |
|----------------------|------------------------|--------|--------|--------|--------|--------|--------|-------|-------|
|                      |                        | 15/7   | 14/6   | 13/5   | 12/4   | 11/3   | 10/2   | 9/1   | 8/0   |
| EMPTY                | 0x2480 to<br>0x24FF    | –      | –      | –      | –      | –      | –      | –     | –     |
|                      |                        | –      | –      | –      | –      | –      | –      | –     | –     |
| FLT5_ BUFFER         | 0x2500 to<br>0x257F- R | data15 | data14 | data13 | data12 | data11 | data10 | data9 | data8 |
|                      |                        | data7  | data6  | data5  | data4  | data3  | data2  | data1 | data0 |
| EMPTY                | 0x2580 to<br>0x25FF    | –      | –      | –      | –      | –      | –      | –     | –     |
|                      |                        | –      | –      | –      | –      | –      | –      | –     | –     |
| FLT6_ BUFFER         | 0x2600 to<br>0x267F- R | data15 | data14 | data13 | data12 | data11 | data10 | data9 | data8 |
|                      |                        | data7  | data6  | data5  | data4  | data3  | data2  | data1 | data0 |
| EMPTY                | 0x2680 to<br>0x26FF    | –      | –      | –      | –      | –      | –      | –     | –     |
|                      |                        | –      | –      | –      | –      | –      | –      | –     | –     |
| FLT7_ BUFFER         | 0x2700 to<br>0x277F- R | data15 | data14 | data13 | data12 | data11 | data10 | data9 | data8 |
|                      |                        | data7  | data6  | data5  | data4  | data3  | data2  | data1 | data0 |
| EMPTY                | 0x2780 to<br>0x27FF    | –      | –      | –      | –      | –      | –      | –     | –     |
|                      |                        | –      | –      | –      | –      | –      | –      | –     | –     |
| FLT8_ BUFFER         | 0x2800 to<br>0x287F- R | data15 | data14 | data13 | data12 | data11 | data10 | data9 | data8 |
|                      |                        | data7  | data6  | data5  | data4  | data3  | data2  | data1 | data0 |
| EMPTY                | 0x2880 to<br>0x28FF    | –      | –      | –      | –      | –      | –      | –     | –     |
|                      |                        | –      | –      | –      | –      | –      | –      | –     | –     |
| FLT9_ BUFFER         | 0x2900 to<br>0x297F- R | data15 | data14 | data13 | data12 | data11 | data10 | data9 | data8 |
|                      |                        | data7  | data6  | data5  | data4  | data3  | data2  | data1 | data0 |
| EMPTY                | 0x2980 to<br>0x29FF    | –      | –      | –      | –      | –      | –      | –     | –     |
|                      |                        | –      | –      | –      | –      | –      | –      | –     | –     |
| FLT10_ BUFFER        | 0x2A00 -<br>0x2A7F- R  | data15 | data14 | data13 | data12 | data11 | data10 | data9 | data8 |
|                      |                        | data7  | data6  | data5  | data4  | data3  | data2  | data1 | data0 |
| EMPTY                | 0x2A80 to<br>0x2AFF    | –      | –      | –      | –      | –      | –      | –     | –     |
|                      |                        | –      | –      | –      | –      | –      | –      | –     | –     |
| FLT11_ BUFFER        | 0x2B00 to<br>0x2B7F- R | data15 | data14 | data13 | data12 | data11 | data10 | data9 | data8 |
|                      |                        | data7  | data6  | data5  | data4  | data3  | data2  | data1 | data0 |
| EMPTY                | 0x2B80 to<br>0x2BFF    | –      | –      | –      | –      | –      | –      | –     | –     |
|                      |                        | –      | –      | –      | –      | –      | –      | –     | –     |



## DVB compliant descrambler

SAA7206H

| REGISTER<br>FUNCTION | ADDRESS<br>(HEX)       | BITS   |        |        |        |        |        |       |       |
|----------------------|------------------------|--------|--------|--------|--------|--------|--------|-------|-------|
|                      |                        | 15/7   | 14/6   | 13/5   | 12/4   | 11/3   | 10/2   | 9/1   | 8/0   |
| FLT12_ BUFFER        | 0x2C00 to<br>0x2C7F- R | data15 | data14 | data13 | data12 | data11 | data10 | data9 | data8 |
|                      |                        | data7  | data6  | data5  | data4  | data3  | data2  | data1 | data0 |
| EMPTY                | 0x2C80 to<br>0x2CFF    | –      | –      | –      | –      | –      | –      | –     | –     |
|                      |                        | –      | –      | –      | –      | –      | –      | –     | –     |
| FLT13_ BUFFER        | 0x2D00 to<br>0x2D7F- R | data15 | data14 | data13 | data12 | data11 | data10 | data9 | data8 |
|                      |                        | data7  | data6  | data5  | data4  | data3  | data2  | data1 | data0 |
| EMPTY                | 0x2D80 to<br>0x2DFF    | –      | –      | –      | –      | –      | –      | –     | –     |
|                      |                        | –      | –      | –      | –      | –      | –      | –     | –     |
| FLT14_ BUFFER        | 0x2E00 to<br>0x2E7F- R | data15 | data14 | data13 | data12 | data11 | data10 | data9 | data8 |
|                      |                        | data7  | data6  | data5  | data4  | data3  | data2  | data1 | data0 |
| EMPTY                | 0x2E80 to<br>0x2EFF    | –      | –      | –      | –      | –      | –      | –     | –     |
|                      |                        | –      | –      | –      | –      | –      | –      | –     | –     |
| FLT15_ BUFFER        | 0x2F00 to<br>0x2F7F- R | data15 | data14 | data13 | data12 | data11 | data10 | data9 | data8 |
|                      |                        | data7  | data6  | data5  | data4  | data3  | data2  | data1 | data0 |
| EMPTY                | 0x2F80 to<br>0x2FFF    | –      | –      | –      | –      | –      | –      | –     | –     |
|                      |                        | –      | –      | –      | –      | –      | –      | –     | –     |
| FLT16_ BUFFER        | 0x3000 to<br>0x307F- R | data15 | data14 | data13 | data12 | data11 | data10 | data9 | data8 |
|                      |                        | data7  | data6  | data5  | data4  | data3  | data2  | data1 | data0 |
| EMPTY                | 0x3080 to<br>0x30FF    | –      | –      | –      | –      | –      | –      | –     | –     |
|                      |                        | –      | –      | –      | –      | –      | –      | –     | –     |
| FLT17_ BUFFER        | 0x3100 to<br>0x317F- R | data15 | data14 | data13 | data12 | data11 | data10 | data9 | data8 |
|                      |                        | data7  | data6  | data5  | data4  | data3  | data2  | data1 | data0 |
| EMPTY                | 0x3180 to<br>0xFFFF    | –      | –      | –      | –      | –      | –      | –     | –     |
|                      |                        | –      | –      | –      | –      | –      | –      | –     | –     |

## DVB compliant descrambler

## SAA7206H

**8 LIMITING VALUES**

In accordance with the Absolute Maximum Rating System (IEC 134).

| SYMBOL             | PARAMETER                                | MIN. | MAX.            | UNIT |
|--------------------|--|------|-----------------|------|
| $V_{DDD(pads)}$    | digital supply voltage for pads (+5 V)   | -0.5 | +6.5            | V    |
| $V_{DDD(core)}$    | digital supply voltage for core (+3.3 V) | -0.5 | +5.0            | V    |
| $V_I$              | DC input voltage                         | -0.5 | $V_{DDD} + 0.5$ | V    |
| $V_O$              | DC output voltage;                       | -0.5 | $V_{DDD} + 0.5$ | V    |
| $I_{DDD}, I_{SSD}$ | DC current; $V_{DD}$ or $V_{SS}$         | -    | 52              | mA   |
| $I_{i(max)}$       | maximum input current                    | -10  | +10             | mA   |
| $I_{o(max)}$       | maximum output current                   | -20  | +20             | mA   |
| $P_{tot}$          | total power dissipation                  | -    | 250             | mW   |
| $T_{stg}$          | storage temperature                      | -65  | +150            | °C   |
| $T_{amb}$          | operating ambient temperature            | 0    | 70              | °C   |

**9 HANDLING**

Inputs and outputs are protected against electrostatic discharges in normal handling. However, to be totally safe, it is desirable to take normal precautions appropriate to handling integrated circuits.

Every pin withstands the ESD test in accordance with "UZW-BO/FQ-B3020"; 0  $\Omega$ , 200 pF Machine Model (300 V).

**10 THERMAL CHARACTERISTICS**

| SYMBOL        | PARAMETER                                   | CONDITIONS  | VALUE | UNIT |
|---------------|---|-------------|-------|------|
| $R_{th\ j-a}$ | thermal resistance from junction to ambient | in free air | 56    | K/W  |

**11 DC CHARACTERISTICS**

$V_{DDD(core)} = 3.3\text{ V} \pm 0.3\text{ V}$ ;  $V_{DDD} = 5\text{ V} \pm 0.5\text{ V}$ ;  $T_{amb} = 0\text{ to }70\text{ °C}$ ; unless otherwise specified.

| SYMBOL          | PARAMETER                          | CONDITIONS  | MIN.         | MAX.         | UNIT          |
|-----------------|------------------------------------|---|--------------|--------------|---------------|
| $I_{DDD(q)}$    | quiescent supply current           | $V_{DDD} = 5.5\text{ V}$ ; note 1                                     | -            | 100          | $\mu\text{A}$ |
| $I_{DDD(core)}$ | digital operating current for core | $V_{DDD} = 5.5\text{ V}$ ;<br>$V_{DDD(core)} = 3.6\text{ V}$ ; note 2 | -            | 42           | mA            |
| $I_{DDD(pads)}$ | digital operating current for pads | $V_{DDD} = 5.5\text{ V}$ ;<br>$V_{DDD(core)} = 3.6\text{ V}$ ; note 2 | -            | 10           | mA            |
| $V_{IL}$        | LOW level input voltage            |   | 0            | 0.8          | V             |
| $V_{IH}$        | HIGH level input voltage           |   | 2.0          | $V_{DDD}$    | V             |
| $I_{LI}$        | input leakage current              | $V_i = 0\text{ V}$ ; $T_{amb} = 25\text{ °C}$                         | -            | 10           | $\mu\text{A}$ |
|                 |                                    | $V_i = 5.5\text{ V}$ ; $T_{amb} = 25\text{ °C}$                       | -            | 10           | $\mu\text{A}$ |
| $V_{OL}$        | LOW level output voltage           | $I_o = 4\text{ mA}$   | 0            | $0.1V_{DDD}$ | V             |
| $V_{OH}$        | HIGH level output voltage          | $I_o = 4\text{ mA}$   | $0.9V_{DDD}$ | $V_{DDD}$    | V             |

**Notes**

- All inputs at  $V_{SSD}$  or  $V_{DDD}$ .
- Operating inputs, unloaded outputs.

## DVB compliant descrambler

## SAA7206H

**12 AC CHARACTERISTICS**

$V_{DD(core)} = 3.3\text{ V} \pm 0.3\text{ V}$ ;  $V_{DD} = 5\text{ V} \pm 0.5\text{ V}$ ;  $T_{amb} = 0\text{ to }70\text{ }^{\circ}\text{C}$ ; unless otherwise specified.

| SYMBOL                                   | PARAMETER   | CONDITIONS     | MIN. | MAX. | UNIT |
|--|---|----------------|------|------|------|
| <b>Input interface; (see Fig.12)</b>     |   |                |      |      |      |
| $C_i$                                    | input capacitance                                   |                | –    | 5    | pF   |
| $T_{cy}$                                 | byte strobe input cycle time<br>(asynchronous mode) | note 1         | 111  | –    | ns   |
| $t_{i(r)(CLK)}$                          | input clock rise time                               |                | –    | 10   | ns   |
| $t_{i(f)(CLK)}$                          | input clock fall time                               |                | –    | 10   | ns   |
| $t_{CLKH}$                               | input clock HIGH time                               |                | 20   | –    | ns   |
| $t_{CLKL}$                               | input clock LOW time                                |                | 20   | –    | ns   |
| $t_{i(r)}$                               | input rise time                                     |                | –    | 10   | ns   |
| $t_{i(f)}$                               | input fall time                                     |                | –    | 10   | ns   |
| $t_{su(i)}$                              | input set-up time                                   |                | 15   | –    | ns   |
| $t_{h(i)}$                               | input hold time                                     |                | 5    | –    | ns   |
| <b>Microcontroller interface</b>         |   |                |      |      |      |
| $C_i$                                    | input capacitance                                   |                | –    | 5    | pF   |
| $T_{cy(CS)}$                             | chip select cycle time                              | see also Fig.9 | 111  | –    | ns   |
| $t_{r(CS)}$                              | chip select rise time                               |                | –    | 10   | ns   |
| $t_{f(CS)}$                              | chip select fall time                               |                | –    | 10   | ns   |
| $t_{CSH}$                                | chip select HIGH time                               |                | 20   | –    | ns   |
| $t_{CSL}$                                | chip select LOW time                                |                | 20   | –    | ns   |
| <b>WRITE CYCLE; (see Figs 14 and 15)</b> |   |                |      |      |      |
| $t_{i(r)}$                               | input rise time                                     |                | –    | 10   | ns   |
| $t_{i(f)}$                               | input fall time                                     |                | –    | 10   | ns   |
| $t_{su(i)}$                              | input set-up time                                   |                | 15   | –    | ns   |
| $t_{h(i)}$                               | input hold time                                     |                | 5    | –    | ns   |
| <b>READ CYCLE; (see Fig.16)</b>          |   |                |      |      |      |
| $t_{CSLr}$                               | chip select LOW time in read mode                   |                | 240  | –    | ns   |
| $t_{o(r)}$                               | output rise time                                    |                | –    | 10   | ns   |
| $t_{o(f)}$                               | output fall time                                    |                | –    | 10   | ns   |
| $t_{o(d)}$                               | output delay time                                   |                | –    | 30   | ns   |
| $t_{o(h)}$                               | output hold time                                    |                | 5    | –    | ns   |
| $t_{oL(Z)}$                              | output low Z time                                   | note 2         | 3    | 30   | ns   |
| $t_{oH(Z)}$                              | output high Z time                                  | note 2         | 3    | 30   | ns   |

## DVB compliant descrambler

## SAA7206H

| SYMBOL                                | PARAMETER                      | CONDITIONS            | MIN. | MAX. | UNIT |
|---------------------------------------|--------------------------------|-----------------------|------|------|------|
| <b>Output interface; (see Fig.13)</b> |                                |                       |      |      |      |
| $C_o$                                 | output capacitance             |                       | –    | 10   | pF   |
| $C_L$                                 | output load capacitance        |                       | –    | 50   | pF   |
| $T_{cy(DCLK)}$                        | output clock cycle time (DCLK) |                       | 111  | –    | ns   |
| $t_{o(r)(DCLK)}$                      | output clock rise time         |                       | –    | 10   | ns   |
| $t_{o(f)(DCLK)}$                      | output clock fall time         |                       | –    | 10   | ns   |
| $t_{DCLKH}$                           | output clock HIGH time         |                       | 20   | –    | ns   |
| $t_{DCLKL}$                           | output clock LOW time          |                       | 20   | –    | ns   |
| $t_{o(r)}$                            | output rise time               |                       | –    | 10   | ns   |
| $t_{o(f)}$                            | output fall time               |                       | –    | 10   | ns   |
| $t_{o(h)}$                            | output hold time               | $C_L = 5 \text{ pF}$  | 3    | –    | ns   |
| $t_{o(d)}$                            | output delay time              | $C_L = 30 \text{ pF}$ | –    | 40   | ns   |

**Notes**

1. In the synchronous mode all input signals are referenced to the descrambler clock which is specified in the output interface part. In the asynchronous mode all input signals are referenced to the MBCLK.
2. Data output is low impedance when both  $(\overline{DCS} = 0)$  AND  $(R/\overline{W} = 1)$ .  $t_{oL(Z)}$  is defined after the last change of both signals which makes the data output low impedance.  $t_{oH(Z)}$  is defined after the first change of both signals which makes the data output high impedance.

DVB compliant descrambler

SAA7206H

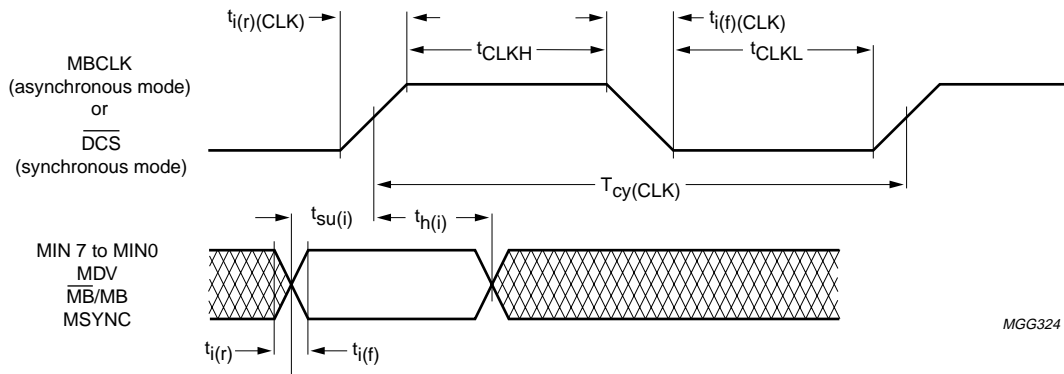

Fig.12 Timing definition of the input interface signals.

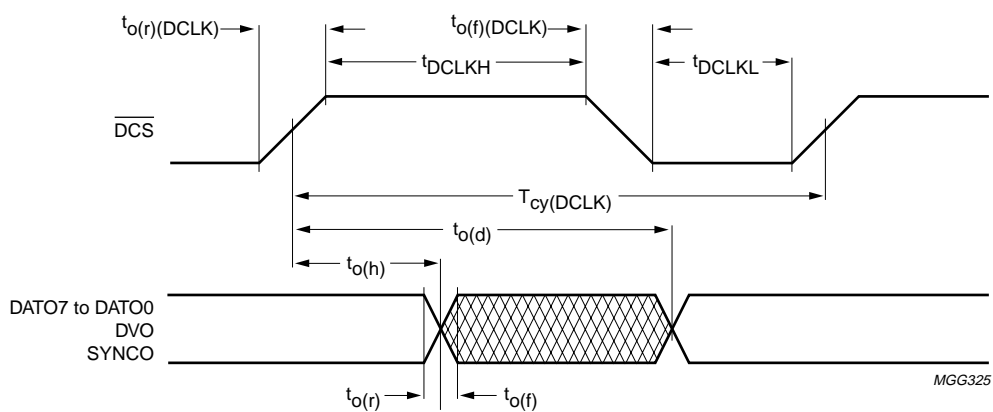

Fig.13 Timing definition of the output interface signals.

DVB compliant descrambler

SAA7206H

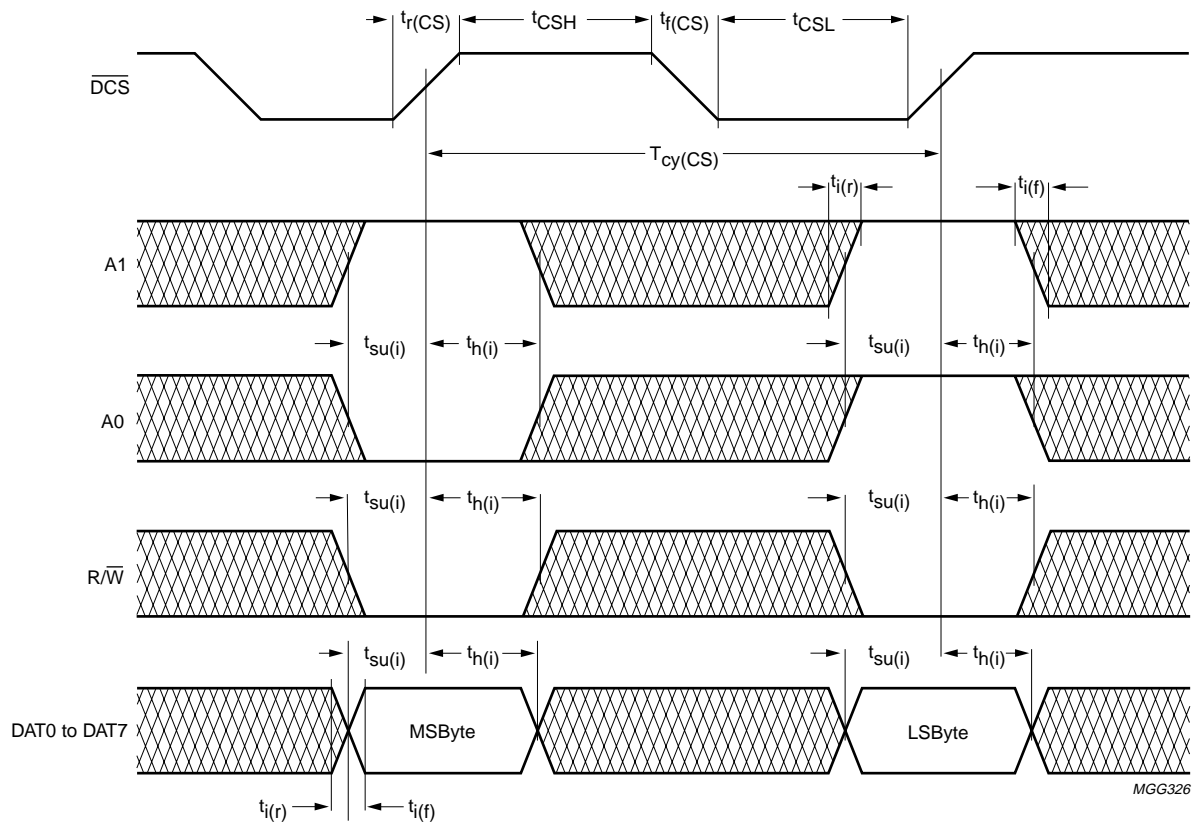

Fig.14 Timing definition of the microcontroller interface signals (address write cycle).

DVB compliant descrambler

SAA7206H

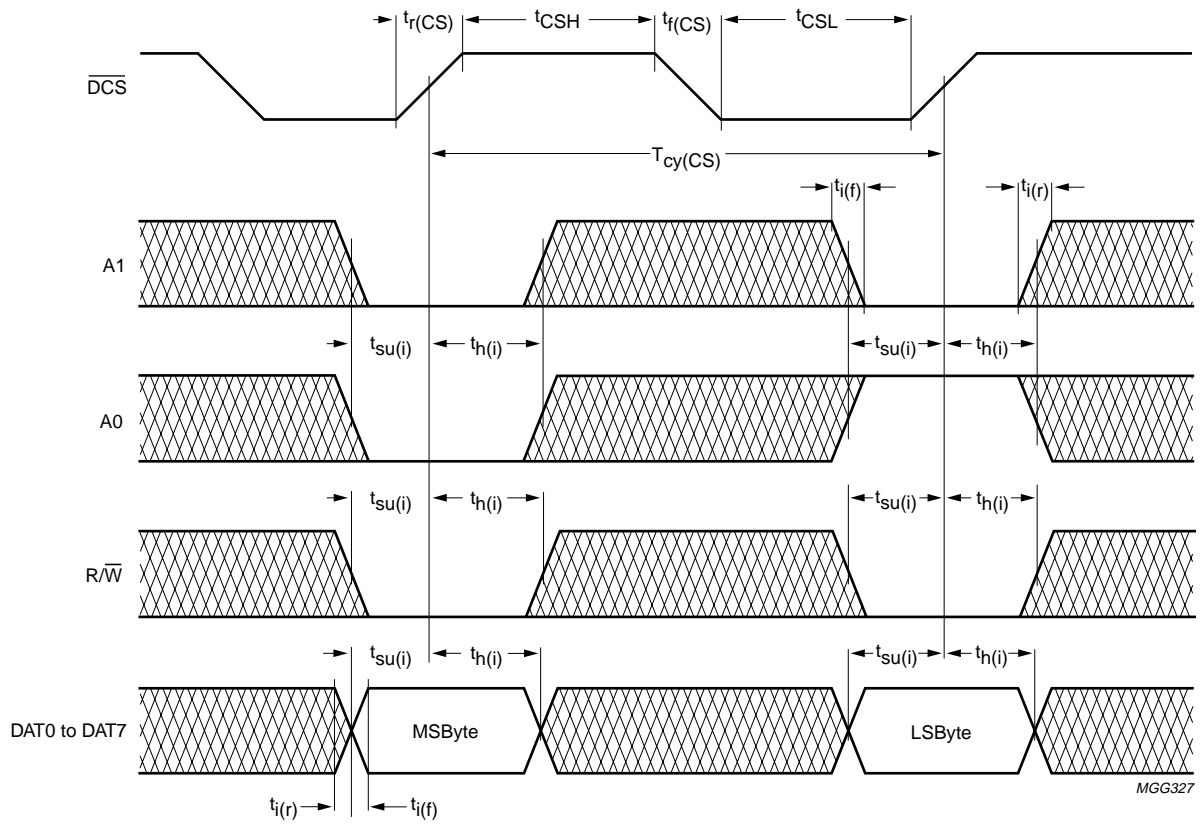

Fig.15 Timing definition of the microcontroller interface signals (data write cycle).

DVB compliant descrambler

SAA7206H

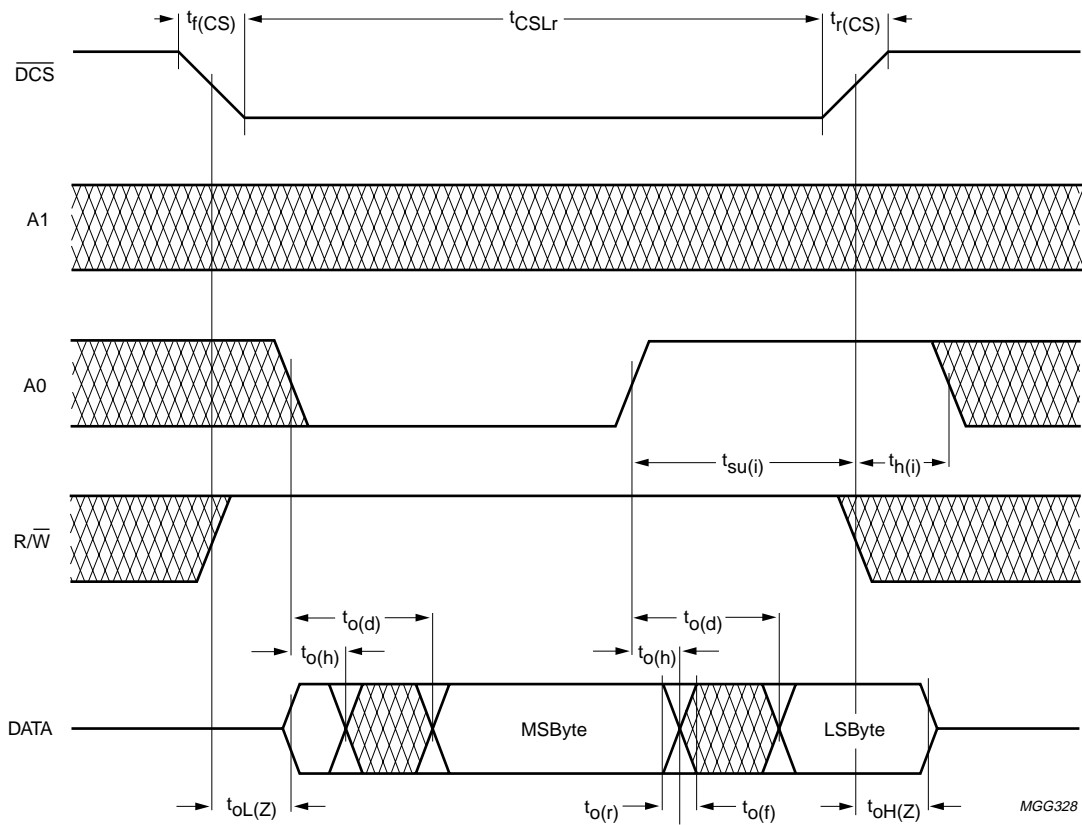

Fig.16 Timing definition of the microcontroller interface signals (read cycle).



DVB compliant descrambler

SAA7206H

13 PACKAGE OUTLINE

QFP64: plastic quad flat package; 64 leads (lead length 1.95 mm); body 14 x 20 x 2.8 mm

SOT319-2

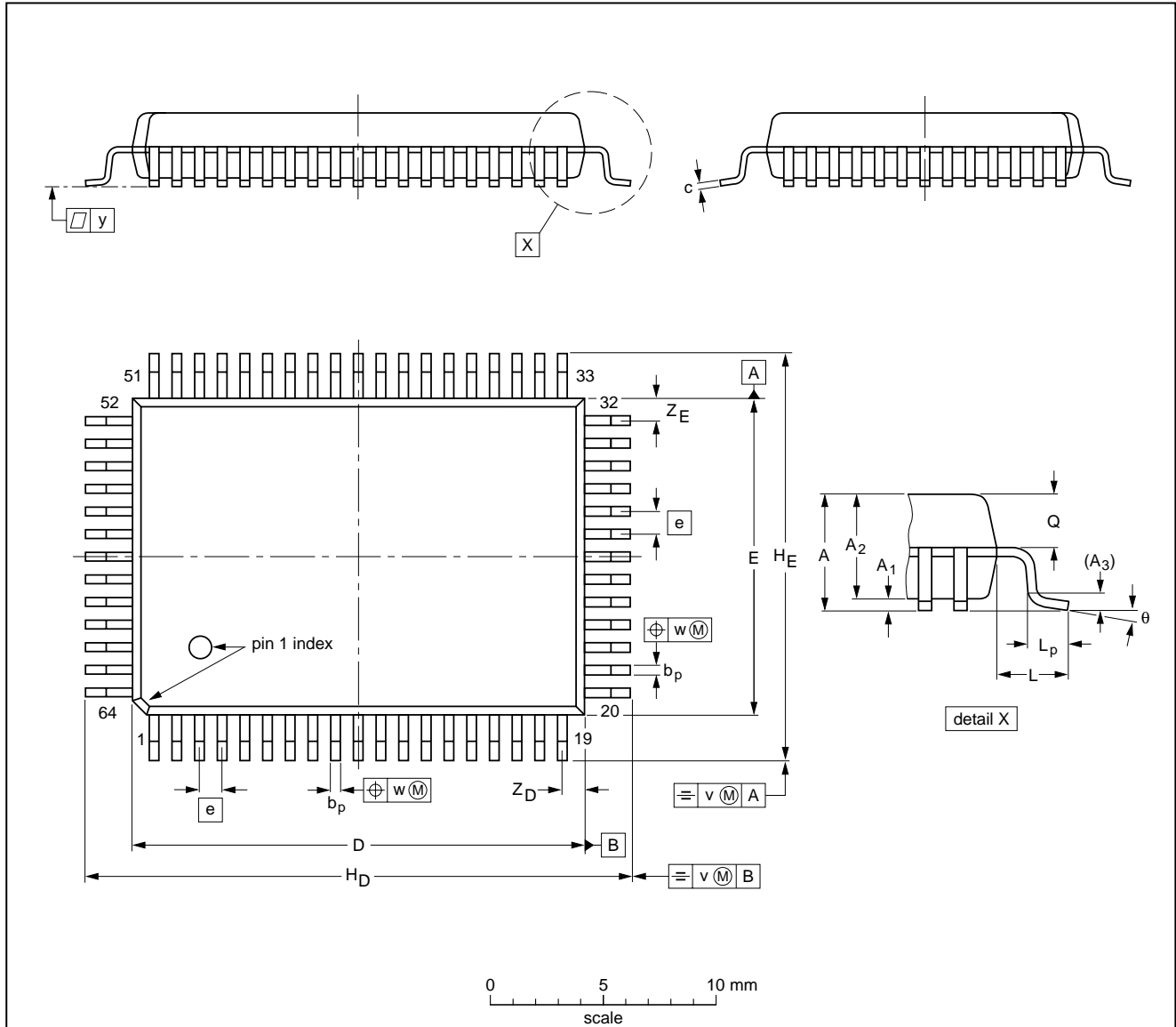

DIMENSIONS (mm are the original dimensions)

| UNIT | A max. | A <sub>1</sub> | A <sub>2</sub> | A <sub>3</sub> | b <sub>p</sub> | c            | D <sup>(1)</sup> | E <sup>(1)</sup> | e | H <sub>D</sub> | H <sub>E</sub> | L    | L <sub>p</sub> | Q          | v   | w   | y   | Z <sub>D</sub> <sup>(1)</sup> | Z <sub>E</sub> <sup>(1)</sup> | θ        |
|------|--------|----------------|----------------|----------------|----------------|--------------|------------------|------------------|---|----------------|----------------|------|----------------|------------|-----|-----|-----|-------------------------------|-------------------------------|----------|
| mm   | 3.20   | 0.25<br>0.05   | 2.90<br>2.65   | 0.25           | 0.50<br>0.35   | 0.25<br>0.14 | 20.1<br>19.9     | 14.1<br>13.9     | 1 | 24.2<br>23.6   | 18.2<br>17.6   | 1.95 | 1.0<br>0.6     | 1.4<br>1.2 | 0.2 | 0.2 | 0.1 | 1.2<br>0.8                    | 1.2<br>0.8                    | 7°<br>0° |

Note

1. Plastic or metal protrusions of 0.25 mm maximum per side are not included.

| OUTLINE VERSION | REFERENCES |       |      |  | EUROPEAN PROJECTION | ISSUE DATE           |
|-----------------|------------|-------|------|--|---------------------|----------------------|
|                 | IEC        | JEDEC | EIAJ |  |                     |                      |
| SOT319-2        |            |       |      |  |                     | 92-11-17<br>95-02-04 |

## DVB compliant descrambler

## SAA7206H

**14 SOLDERING****14.1 Introduction**

There is no soldering method that is ideal for all IC packages. Wave soldering is often preferred when through-hole and surface mounted components are mixed on one printed-circuit board. However, wave soldering is not always suitable for surface mounted ICs, or for printed-circuits with high population densities. In these situations reflow soldering is often used.

This text gives a very brief insight to a complex technology. A more in-depth account of soldering ICs can be found in our "IC Package Databook" (order code 9398 652 90011).

**14.2 Reflow soldering**

Reflow soldering techniques are suitable for all QFP and SO packages.

The choice of heating method may be influenced by larger plastic QFP packages (44 leads, or more). If infrared or vapour phase heating is used and the large packages are not absolutely dry (less than 0.1% moisture content by weight), vaporization of the small amount of moisture in them can cause cracking of the plastic body. For more information, refer to the Drypack chapter in our "Quality Reference Manual" (order code 9397 750 00192).

Reflow soldering requires solder paste (a suspension of fine solder particles, flux and binding agent) to be applied to the printed-circuit board by screen printing, stencilling or pressure-syringe dispensing before package placement.

Several techniques exist for reflowing; for example, thermal conduction by heated belt. Dwell times vary between 50 and 300 seconds depending on heating method. Typical reflow temperatures range from 215 to 250 °C.

Preheating is necessary to dry the paste and evaporate the binding agent. Preheating duration: 45 minutes at 45 °C.

**14.3 Wave soldering****14.3.1 QFP**

Wave soldering is **not** recommended for QFP packages. This is because of the likelihood of solder bridging due to closely-spaced leads and the possibility of incomplete solder penetration in multi-lead devices.

If wave soldering cannot be avoided, the following conditions must be observed:

- **A double-wave (a turbulent wave with high upward pressure followed by a smooth laminar wave) soldering technique should be used.**
- **The footprint must be at an angle of 45° to the board direction and must incorporate solder thieves downstream and at the side corners.**

**Even with these conditions, do not consider wave soldering the following packages: QFP52 (SOT379-1), QFP100 (SOT317-1), QFP100 (SOT317-2), QFP100 (SOT382-1) or QFP160 (SOT322-1).**

**14.3.2 SO**

Wave soldering techniques can be used for all SO packages if the following conditions are observed:

- A double-wave (a turbulent wave with high upward pressure followed by a smooth laminar wave) soldering technique should be used.
- The longitudinal axis of the package footprint must be parallel to the solder flow.
- The package footprint must incorporate solder thieves at the downstream end.

**14.3.3 METHOD (QFP AND SO)**

During placement and before soldering, the package must be fixed with a droplet of adhesive. The adhesive can be applied by screen printing, pin transfer or syringe dispensing. The package can be soldered after the adhesive is cured.

Maximum permissible solder temperature is 260 °C, and maximum duration of package immersion in solder is 10 seconds, if cooled to less than 150 °C within 6 seconds. Typical dwell time is 4 seconds at 250 °C.

A mildly-activated flux will eliminate the need for removal of corrosive residues in most applications.

**14.4 Repairing soldered joints**

Fix the component by first soldering two diagonally-opposite end leads. Use only a low voltage soldering iron (less than 24 V) applied to the flat part of the lead. Contact time must be limited to 10 seconds at up to 300 °C. When using a dedicated tool, all other leads can be soldered in one operation within 2 to 5 seconds between 270 and 320 °C.

## DVB compliant descrambler

SAA7206H

**15 DEFINITIONS**

|   |   |
|---|---|
| <b>Data sheet status</b>  |   |
| Objective specification   | This data sheet contains target or goal specifications for product development.       |
| Preliminary specification   | This data sheet contains preliminary data; supplementary data may be published later. |
| Product specification   | This data sheet contains final product specifications.                                |
| <b>Limiting values</b>  |   |
| Limiting values given are in accordance with the Absolute Maximum Rating System (IEC 134). Stress above one or more of the limiting values may cause permanent damage to the device. These are stress ratings only and operation of the device at these or at any other conditions above those given in the Characteristics sections of the specification is not implied. Exposure to limiting values for extended periods may affect device reliability. |   |
| <b>Application information</b>  |   |
| Where application information is given, it is advisory and does not form part of the specification.   |   |

**16 LIFE SUPPORT APPLICATIONS**

These products are not designed for use in life support appliances, devices, or systems where malfunction of these products can reasonably be expected to result in personal injury. Philips customers using or selling these products for use in such applications do so at their own risk and agree to fully indemnify Philips for any damages resulting from such improper use or sale.

# Philips Semiconductors – a worldwide company

**Argentina:** see South America

**Australia:** 34 Waterloo Road, NORTH RYDE, NSW 2113,  
Tel. +61 2 9805 4455, Fax. +61 2 9805 4466

**Austria:** Computerstr. 6, A-1101 WIEN, P.O. Box 213,  
Tel. +43 1 60 101, Fax. +43 1 60 101 1210

**Belarus:** Hotel Minsk Business Center, Bld. 3, r. 1211, Volodarski Str. 6,  
220050 MINSK, Tel. +375 172 200 733, Fax. +375 172 200 773

**Belgium:** see The Netherlands

**Brazil:** see South America

**Bulgaria:** Philips Bulgaria Ltd., Energoproject, 15th floor,  
51 James Bourchier Blvd., 1407 SOFIA,  
Tel. +359 2 689 211, Fax. +359 2 689 102

**Canada:** PHILIPS SEMICONDUCTORS/COMPONENTS,  
Tel. +1 800 234 7381

**China/Hong Kong:** 501 Hong Kong Industrial Technology Centre,  
72 Tat Chee Avenue, Kowloon Tong, HONG KONG,  
Tel. +852 2319 7888, Fax. +852 2319 7700

**Colombia:** see South America

**Czech Republic:** see Austria

**Denmark:** Prags Boulevard 80, PB 1919, DK-2300 COPENHAGEN S,  
Tel. +45 32 88 2636, Fax. +45 31 57 1949

**Finland:** Sinikalliontie 3, FIN-02630 ESPOO,  
Tel. +358 9 615800, Fax. +358 9 61580/xxx

**France:** 4 Rue du Port-aux-Vins, BP317, 92156 SURESNES Cedex,  
Tel. +33 1 40 99 6161, Fax. +33 1 40 99 6427

**Germany:** Hammerbrookstraße 69, D-20097 HAMBURG,  
Tel. +49 40 23 53 60, Fax. +49 40 23 536 300

**Greece:** No. 15, 25th March Street, GR 17778 TAVROS/ATHENS,  
Tel. +30 1 4894 339/239, Fax. +30 1 4814 240

**Hungary:** see Austria

**India:** Philips INDIA Ltd, Shivsagar Estate, A Block, Dr. Annie Besant Rd.  
Worli, MUMBAI 400 018, Tel. +91 22 4938 541, Fax. +91 22 4938 722

**Indonesia:** see Singapore

**Ireland:** Newstead, Clonskeagh, DUBLIN 14,  
Tel. +353 1 7640 000, Fax. +353 1 7640 200

**Israel:** RAPAC Electronics, 7 Kehilat Saloniki St, TEL AVIV 61180,  
Tel. +972 3 645 0444, Fax. +972 3 649 1007

**Italy:** PHILIPS SEMICONDUCTORS, Piazza IV Novembre 3,  
20124 MILANO, Tel. +39 2 6752 2531, Fax. +39 2 6752 2557

**Japan:** Philips Bldg 13-37, Kohnan 2-chome, Minato-ku, TOKYO 108,  
Tel. +81 3 3740 5130, Fax. +81 3 3740 5077

**Korea:** Philips House, 260-199 Itaewon-dong, Yongsan-ku, SEOUL,  
Tel. +82 2 709 1412, Fax. +82 2 709 1415

**Malaysia:** No. 76 Jalan Universiti, 46200 PETALING JAYA, SELANGOR,  
Tel. +60 3 750 5214, Fax. +60 3 757 4880

**Mexico:** 5900 Gateway East, Suite 200, EL PASO, TEXAS 79905,  
Tel. +9-5 800 234 7381

**Middle East:** see Italy

**Netherlands:** Postbus 90050, 5600 PB EINDHOVEN, Bldg. VB,  
Tel. +31 40 27 82785, Fax. +31 40 27 88399

**New Zealand:** 2 Wagener Place, C.P.O. Box 1041, AUCKLAND,  
Tel. +64 9 849 4160, Fax. +64 9 849 7811

**Norway:** Box 1, Manglerud 0612, OSLO,  
Tel. +47 22 74 8000, Fax. +47 22 74 8341

**Philippines:** Philips Semiconductors Philippines Inc.,  
106 Valero St. Salcedo Village, P.O. Box 2108 MCC, MAKATI,  
Metro MANILA, Tel. +63 2 816 6380, Fax. +63 2 817 3474

**Poland:** Ul. Lukiska 10, PL 04-123 WARSZAWA,  
Tel. +48 22 612 2831, Fax. +48 22 612 2327

**Portugal:** see Spain

**Romania:** see Italy

**Russia:** Philips Russia, Ul. Usatcheva 35A, 119048 MOSCOW,  
Tel. +7 095 247 9145, Fax. +7 095 247 9144

**Singapore:** Lorong 1, Toa Payoh, SINGAPORE 1231,  
Tel. +65 350 2538, Fax. +65 251 6500

**Slovakia:** see Austria

**Slovenia:** see Italy

**South Africa:** S.A. PHILIPS Pty Ltd., 195-215 Main Road Martindale,  
2092 JOHANNESBURG, P.O. Box 7430 Johannesburg 2000,  
Tel. +27 11 470 5911, Fax. +27 11 470 5494

**South America:** Rua do Rocio 220, 5th floor, Suite 51,  
04552-903 São Paulo, SÃO PAULO - SP, Brazil,  
Tel. +55 11 821 2333, Fax. +55 11 829 1849

**Spain:** Balmes 22, 08007 BARCELONA,  
Tel. +34 3 301 6312, Fax. +34 3 301 4107

**Sweden:** Kottbygatan 7, Akalla, S-16485 STOCKHOLM,  
Tel. +46 8 632 2000, Fax. +46 8 632 2745

**Switzerland:** Allmendstrasse 140, CH-8027 ZÜRICH,  
Tel. +41 1 488 2686, Fax. +41 1 481 7730

**Taiwan:** PHILIPS TAIWAN Ltd., 23-30F, 66,  
Chung Hsiao West Road, Sec. 1, P.O. Box 22978,  
TAIPEI 100, Tel. +886 2 382 4443, Fax. +886 2 382 4444

**Thailand:** PHILIPS ELECTRONICS (THAILAND) Ltd.,  
209/2 Sanpavuth-Bangna Road Prakanong, BANGKOK 10260,  
Tel. +66 2 745 4090, Fax. +66 2 398 0793

**Turkey:** Talatpasa Cad. No. 5, 80640 GÜLTEPE/ISTANBUL,  
Tel. +90 212 279 2770, Fax. +90 212 282 6707

**Ukraine:** PHILIPS UKRAINE, 4 Patrice Lumumba str., Building B, Floor 7,  
252042 KIEV, Tel. +380 44 264 2776, Fax. +380 44 268 0461

**United Kingdom:** Philips Semiconductors Ltd., 276 Bath Road, Hayes,  
MIDDLESEX UB3 5BX, Tel. +44 181 730 5000, Fax. +44 181 754 8421

**United States:** 811 East Arques Avenue, SUNNYVALE, CA 94088-3409,  
Tel. +1 800 234 7381

**Uruguay:** see South America

**Vietnam:** see Singapore

**Yugoslavia:** PHILIPS, Trg N. Pasica 5/v, 11000 BEOGRAD,  
Tel. +381 11 625 344, Fax. +381 11 635 777

**For all other countries apply to:** Philips Semiconductors, Marketing & Sales Communications,  
Building BE-p, P.O. Box 218, 5600 MD EINDHOVEN, The Netherlands, Fax. +31 40 27 24825

**Internet:** <http://www.semiconductors.philips.com>

© Philips Electronics N.V. 1996

SCA52

All rights are reserved. Reproduction in whole or in part is prohibited without the prior written consent of the copyright owner.

The information presented in this document does not form part of any quotation or contract, is believed to be accurate and reliable and may be changed without notice. No liability will be accepted by the publisher for any consequence of its use. Publication thereof does not convey nor imply any license under patent- or other industrial or intellectual property rights.

Printed in The Netherlands

537021/1200/02/pp52

Date of release: 1996 Oct 09

Document order number: 9397 750 01331

*Let's make things better.*

**Philips**  
Semiconductors



**PHILIPS**